



THE GLOBAL STANDARD  
FOR LIVESTOCK DATA

# ICAR Guidelines for Routine Checking Manual of the Milk Meters

**Electronic Milk Meter [EMM] Milk Meter by Tru-Test**

Version June 2018

Network. Guidelines. Certification.

---

# Table of Contents

---

<b>1</b>	<b>Preliminary information .....</b>	<b>3</b>
<b>2</b>	<b>Equipment required .....</b>	<b>3</b>
2.1	Test liquid .....	3
<b>3</b>	<b>Before you start .....</b>	<b>4</b>
<b>4</b>	<b>Testing Tru-Test Electronic Milk Meters (EMM's) .....</b>	<b>4</b>
<b>5</b>	<b>Testing Tru-Test Mechanical Milk Meters.....</b>	<b>5</b>
<b>6</b>	<b>Further checks.....</b>	<b>6</b>
<b>7</b>	<b>Servicing required.....</b>	<b>6</b>
<b>8</b>	<b>Testing repaired Milk Meters .....</b>	<b>6</b>
<b>9</b>	<b>Test date label .....</b>	<b>6</b>



## 1 Preliminary information

### How often should Tru-Test Milk Meters be water tested?

Tru-Test recommends that ALL Milk Meters are water tested at least once every 12 months.

### How do I know when water testing is due?

When a Milk Meter is tested, a label is affixed to it showing the date the test was performed. The Milk Meter should be tested within 12 months of this date. See “Test date label” in the User Manual.

## 2 Equipment required

To test Tru-Test Electronic Milk Meters (EMM's), test rigs manufactured before 2005 must be modified with an air admission hole and rubber sleeve (MMG00015: fast flow test rig inlet tube with a rubber sleeve).

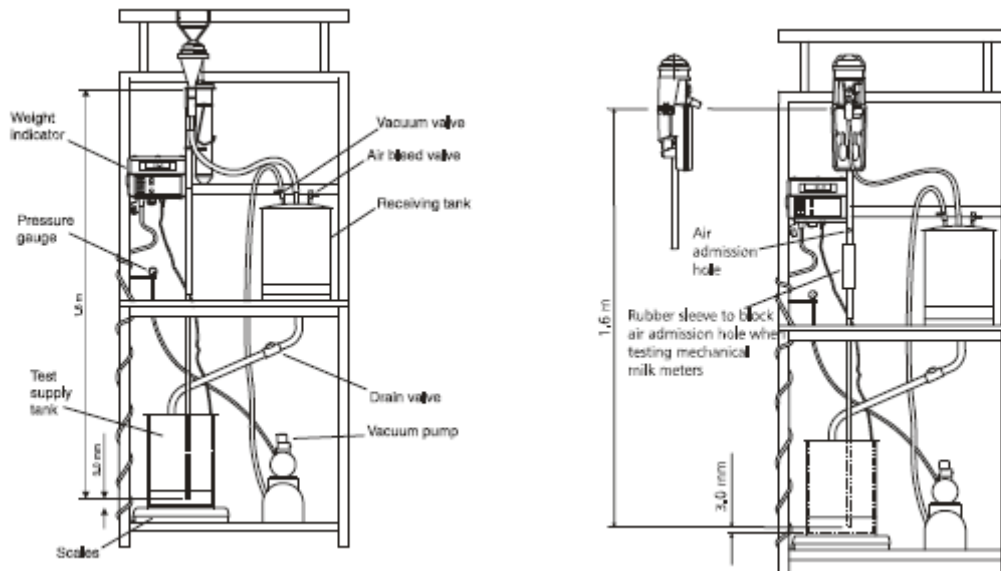

### 2.1 Test liquid

- Normal tap water, refreshed regularly for hygiene purposes.
- For Tru-Test EMM's a solution of regular tap water and Potassium Iodide (KI) is required.
- Mix 110 g of Potassium Iodide into 20 L of water. Ensure the Potassium Iodide is well dissolved. For hygiene purposes, the test liquid should be made on the same day it is to be used.

### **3 Before you start**

#### **Clean the exterior of the Milk Meters**

Clean the outside of each Milk Meter using warm water and commonly used dairy detergent at the manufacturer's recommended strength. Finish the cleaning operation with a warm water rinse.

---

*Note:* The inside of the Milk Meter is routinely cleaned during the dairy plant wash at the end of each milking session.

---

#### **Visually check the Milk Meters**

Check the readability of the calibrated scale (mechanical Milk Meters) and that the clamping/bracket mechanism is hanging straight.

The flask calibration print should be easily read from a distance of 1 metre. Replace old flasks with a Tru-Test ICAR approved flask.

#### **Replace all rubber components in the Milk Meters**

Tru-Test recommends that ALL rubberware components on Milk Meters be replaced at least annually to prevent air leaks, inaccuracies and bacterial contamination.

#### **Lubricate the Milk Meters**

Disassemble, wash and lubricate the sample valve, wash valve and flask gasket with a food grade silicone lubricant for each Milk Meter. See the applicable Operating Manual for your Milk Meter for instructions.

#### **Check the water test rig**

The water test rig must be checked in order to guarantee its accuracy. Check that the test rig lifts 16.0 kg of water to 1.60 m by 50 kPa. Ensure that the vacuum recovers to 50kPa immediately after opening the inlet tube valve.

### **4 Testing Tru-Test Electronic Milk Meters (EMM's)**

#### **Check the software**

Ensure that the EMM and Data Handler software is up to date. The EMM should be running software build m3\_7e (or newer), and the Data Handler software build r3\_3e (or newer). Ensure that the Data Handler has been configured with the correct RC file by turning on the Data Handler. "Herd: ffr" should be displayed. A correct version of the RC file can be supplied by your Tru-Test representative.

To upload the RC file to the Data Handler:

1. Save the RC file in an appropriate directory on your PC.
2. Start LinkTTEMM and open the RC file.
3. Connect the Data Handler to a Data Transfer Unit and turn it on.
4. Upload the file from LinkTTEMM to the Data Handler.
5. Disconnect the Data Handler from the Data Transfer Unit.

*Note:* The RC file only has to be loaded once into the Data Handler. The settings will remain in the Data Handler until a new RC file is loaded.

---

### **Water test an Electronic Milk Meter**

---

*Note:* Water testing will take about 90 seconds per Milk Meter.

---

6. Turn on the Data Handler. “TRU-TEST HERD MANAGEMENT”, “Herd: ffr” is displayed.
7. Turn on the EMM. Push the wash valve up into the milk position. Wait for the sample rotor to come to a stop in the milk position.
8. Mount the EMM on the test rig. Visually check that the meter is vertical (within +/- 0.5 degrees).
9. Enter a unique animal ID (for this testing session) into the Data Handler and press **Select** on the EMM. A warning is displayed on the Data Handler if the EMM is not vertical.
10. Draw 16.0 L of test liquid through the EMM.
11. Wait for 3 seconds and close the inlet tube valve.
12. Wait for 10 seconds until the fluid settles.
13. Press Select on the EMM. The Data Handler displays the yield. Note the displayed number. The result should be 16.0-17.0 kg (16.5 ± 3%). The Data Handler will indicate whether the result is a Pass or a Fail.
14. Press **Finished Milking Release Sample** on the EMM.
15. Once the EMM is empty, close the vacuum valve, remove the EMM from the rig, and open the inlet tube valve.

Repeat the test for each EMM

### **Turn off the Milk Meters and the Data Handler**

1. Turn off the EMM's using the Data Handler. See “Tru-Test Electronic Milk Meter Operating Instructions” for instructions.
2. Turn off the Data Handler

### **Download and interpret the test data**

1. Connect the Data Handler to a PC.
2. Turn on the Data Handler and download the test data using LinkTTEMM.

Each EMM should have a reading of 16.0-17.0 kg (16.5 ± 3%).

## **5 Testing Tru-Test Mechanical Milk Meters**

### **Water test a Mechanical Milk Meter**

---

*Note:* Testing will take about 90 seconds per Milk Meter.

---

1. Mount the Milk Meter on the test rig. Visually check that the Meter is vertical (within +/- 0.5 degrees).
2. Draw 16.0 L of test liquid through the Milk Meter, close the inlet tube valve.



3. Read the scale on the Milk Meter flask. The result should be 16.0-17.0 kg (16.5 ± 3%).
4. Empty the Milk Meter.
5. Once the Milk Meter is empty, close the vacuum valve, remove the Milk Meter from the rig, and open the inlet tube valve.

Repeat the test for each Milk Meter.

## 6 Further checks

If the reading for a particular Milk Meter is outside these limits:

1. Check the Milk Meter for air leaks around the cover o-ring, flask gasket, air admission valve and the sampling valve at the base of the Milk Meter.
2. Check the Milk Meter cover and sampling nozzle for damage and obstructions (e.g. hair, grit).  
Replace these components if necessary, or remove any obstructions.
3. Repeat the test.

If, after this, a particular Milk Meter measurement does not fall within the range of 16.0-17.0 kg, disassemble and check the Milk Meter, then reassemble and test it again

## 7 Servicing required

If a Milk Meter reading is still inaccurate, send the faulty Milk Meter sent to a Tru-Test Service Centre for repair.

## 8 Testing repaired Milk Meters

Where a measuring nozzle has been replaced on the Milk Meter, the Meter must be checked for accuracy using the test methods described above.

## 9 Test date label

When a Milk Meter has been tested, a “Test date” label must be affixed to the Milk Meter. This verifies that the Milk Meter has been tested and indicates the date the test was done. The label is colour coded by year, with the months of the year around the perimeter. Affix a label to the Milk Meter body with the number of the month of test (e.g. March=3, November=11) at the top of the Milk Meter. The Milk Meter must be tested within 12 months of the date shown.



Example shows next test due: February 2007.