

Sampler for Lely Astronaut

Sampling device



Operator Manual

EN – English Original
5.1504.00XX.0







Dear customer,

Thank you for purchasing the Sampler for Lely Astronaut.

This product is designed and manufactured by a company other than Lely (a so called third-party product). Who are the first and second party? Technically speaking, Lely is the "first party." "Second party" usually refers to the person using the product.

The producing company of this product has been selected and assessed to meet all Lely requirements. This product is extensively tested and approved by Lely to meet the Lely quality standards.

If you need help with this third-party product, please contact your Lely point of purchase. Your Lely point of purchase handles the warranty of this product. For this product the producing company remains the Legal manufacturer according to the applicable EU-regulations.

Our Lely service technicians are trained to service all our products, including third-party products. Spare parts can be obtained through your Lely point of purchase.





Trademarks, Copyright and Disclaimer

The information given in this publication is provided for information purposes only and does not constitute an offer for sale. Certain products may not be available in individual countries and products supplied may differ from those illustrated.

No part of this publication may be copied or published by means of printing, photocopying, microfilm or any other process whatsoever without prior permission in writing by Lely Holding b.v. Although the contents of this publication have been compiled with the greatest possible care, Lely cannot accept liability for any damage that might arise from errors or omissions in this publication.

For more information on the right on exclusive use please refer to our trademark notice on www.Lely.com.

Version of the manual: 09/23

Copyright © 2023 Lely Industries N.V.
All rights reserved

Lely Industries N.V.
Cornelis van der Lelylaan 1
3147 PB Maassluis
The Netherlands
Phone: +31 (0)88 1228221
Fax: +31 (0)88 1228222
Website: www.lely.com



List of included A mendments

No:	Issue Date (yy/mm)	Chapter(s)	Remarks
1	22/01	Preface, 3.1, 3.4 , 3.6, 4.4 and 11	New Version of the Manual Include new version of the device 54, 80, 110
2	23/06	5.2.3 5.2.4	Include length and diameter of the milk hose Include new valve for A5 connection





Preface

Manual Contents

This manual contains the information necessary to operate the Sampler for Lely Astronaut (hereafter: sampler).

Study and understand this information thoroughly before you operate the sampler. Failure to do so could result in personal injury or damage to equipment. Please consult your local Lely service provider if you do not understand the information in this manual, or if you need additional information.

All information in this manual has been compiled with care. Lely shall not be liable for errors or faults in this manual. The recommendations are meant to serve as guidelines. All instructions, pictures and specifications in this manual are based on the latest information that was available at the time of publication. Your sampler may comprise improvements, features or options that are not covered in this manual.

Applicability

The table below shows the type numbers of sampler for which this manual is applicable.

Model	Type number
ARSD L 54	TYPE XX (XX vial type)
ARSD 60	TYPE XX
ARSD L 72	TYPE XX
ARSD LA 80	TYPE XX
ARSD L 90	TYPE XX
ARSD LA 110	TYPE XX
ARSD LA 132	TYPE XX

Standard Torque Loading of Parts

All the nuts, bolts and screws used on the sampler are torque tightened to standard torque loadings applicable to the construction materials used.

If a part has a non-standard torque loading, it is specified in the applicable part of the manual.

Registration

The type and serial number plate is attached to the sampler. Always include the type and serial numbers of your machine when you contact your local Lely service provider or order spare parts.



Figure 1. Type and Serial Number Plate

Legal manufacturer

Sayca Automatización
C/Domingo Fontan, 4
28028 Madrid
Spain

We suggest you complete the table below with the type and serial numbers of your sampler. This makes sure you can easily find the information.

Type number
Serial number

Contact Number Local Service Provider

We suggest you write the telephone number and email address of your local service provider contact in the table below. This makes sure you can easily find the information.

Telephone number
E-mail address

Table of Contents

1	Introduction	14
2	Safety	17
2.1	Introduction	17
2.2	Signal Icons.....	17
2.3	Safety Instructions	18
2.3.1	General Safety.....	18
2.3.2	Operating Safety	18
2.3.4	Maintenance Safety	18
2.4	Safety Decals.....	18
2.4.1	Safety Decal Messages.....	18
2.4.2	Maintenance of Safety Decals	18
2.4.3	Installation of Safety Decals	18
3	Specifications	19
3.1	Sampler 54 vials.....	19
3.2	Sampler 60 vials.....	19
3.3	Sampler 72 vials.....	19
3.4	Sampler 80 vials.....	20
3.5	Sampler 90 vials.....	20
3.6	Sampler 110 vials	20
3.7	Sampler 132 vials	21
4	Description and Operation	23
4.1	Description	23
4.2	Component Description	23
4.3	How the sampler works	24
4.4	How the sampler changes to the next row	24
4.5	Operation	25
5	Operating Instructions	28
5.1	Transporting the sampler.	28
5.2	Connecting the sampler.	29
5.2.1	Installing the sampler	29
5.2.2	Setting the robot for the sampler.	32
5.2.3	Connecting the milk tube sampler to the milk jar	35
5.2.4	Connect the air pressure between the sampler and the Robot	41
5.2.5	Starting the session milk sampling	44
5.3	Closing the milk sampling session	45
5.4	Take the vials and clean the sampler	47
5.5	Print the list of sample details	47
5.5.1	For the software T4C.....	47
5.5.2	For the software Horizon	47
6	Installation	51
6.1	Introduction	51

6.2	Preparation	51
6.2.1	Preparation by the Owner	51
6.2.2	Preparation by the Lely Service Provider	51
6.2.3	List of supplied parts	51
7	Cleaning and maintenance	52
7.1	Cleaning the filling system	52
7.1.1	Unmounting the filling system	52
7.1.2	Removing the air tube	52
7.1.3	Disassembly of the milk deposit assembly	53
7.1.4	Cleaning the filling system and hoses.....	53
7.1.5	Cleaning the protecting case and crown	54
7.1.6	Removing the silicone hose from the filling system	54
7.1.7	Removing silicone tube from the milk deposit	55
7.1.8	Recommendation for fitting the silicon tube	55
7.1.9	Mounting the filling system	56
7.1.10	Reconnecting the air tube	56
7.2	Maintenance of the stainless steel crown	57
7.2.1	Disassembling the crown	57
7.2.2	Detach the crown from the case	57
7.2.3	Removing the crown from the case	58
7.2.4	Install the crown in the case.	58
7.3	Scheduled maintenance	59
8	Pneumatic circuit	60
8.1	Introduction	60
8.2	Air components parts	60
8.3	Pneumatic circuit	61
8.4	How the system works.	62
8.4.1	Initial state	62
8.4.2	Air pressure activated	62
8.4.3	Next position	63
8.5	Test and adjustment	64
9	Troubleshooting	65
10	Disposal	66
11	Main spare parts	67
12	Index	68

1 Introduction

The sampler is a removable, external sampling device for Lely Astronaut milking robots. Once connected, the sampler can automatically collect up to 54, 60, 72, 90 or 132 milk samples (depending on the model).

The system provides three functions:

1. Transport of milk from the point of collection on the milking robot
2. Filling a calibrated milk sample
3. Movement of the turntable that holds the sampling bottles.

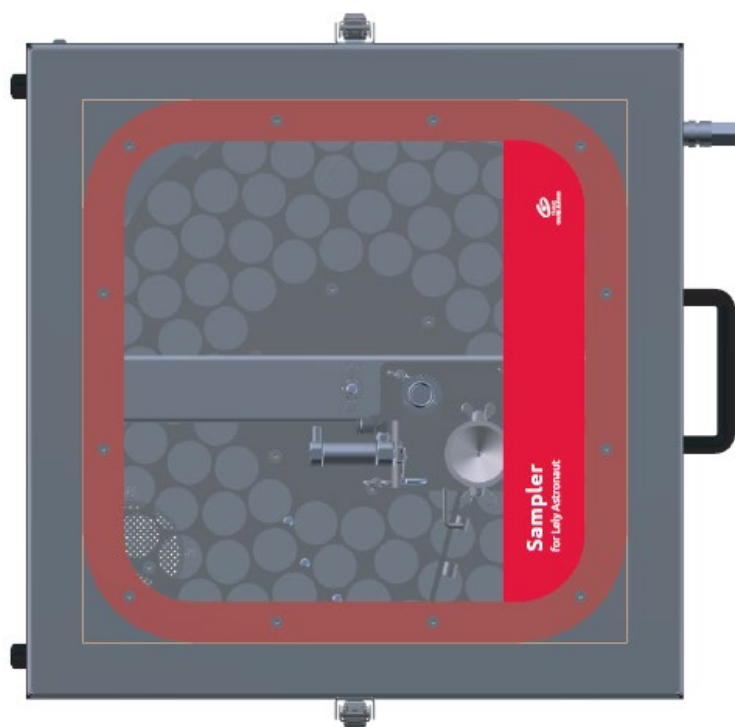

Figure 2. overview of the sampler





2 Safety

2.1 Introduction

The design and manufacture of the sampler took into account the risk of danger in accordance to the appropriate standards. General safety is guaranteed if the user complies with the safety instructions.

It is the user's responsibility to ensure that the following measures are observed:

- Anyone operating the sampler must have read the manual.
- Users of the sampler shall always have access to the manual.
- Safety instructions shall always be adhered to.
- The product can only be used within the environment described.
- Safety devices should be checked regularly.
- Maintenance shall only be carried out by qualified personnel.
- Safety symbols, labels and stickers on the sampler should be replaced if lost or illegible.
- Untrained personnel must not use the sampler. Prior training should always be provided.

2.2 Signal Icons

Note the use of the signal words DANGER, WARNING and CAUTION with the safety messages. The signal word for each message uses the following guidelines:



Danger: indicates an imminently hazardous situation that, if not avoided, will result in death or serious injury.



Warning: indicates a potentially hazardous situation that, if not avoided, could result in death or serious injury.



Caution: indicates a potentially hazardous situation that, if not avoided, may result in minor or moderate injury.



Notice. Is used to address practices not related to physical injury e.g. property damage.



Tip. Indicates information that may help the reader, but not hazard related.

2.3 Safety Instructions

2.3.1 General Safety

YOU are responsible for the SAFE operation and maintenance of your robotic milking system. YOU must make sure that you and anyone else who is going to operate, maintain or work in the vicinity of the milking robot knows all the related SAFETY information in this manual.

YOU are the key to safety. Good safety practices protect you and the people around you. Make these practices a working part of your safety program. Make sure EVERYONE who operates, maintains, or works near the milking robot obeys the safety precautions. Do not risk injury or death by ignoring good safety practices

2.3.2 Operating Safety

- Sampler owners must train operators before they operate the sampler and the milking robot. This training must be repeated at least annually.
- The operator must read, understand, and obey all safety and operating instructions in the manual.
- Anyone who has not read and understood all safety and operating instructions is not permitted to operate the milking robot or the sampler.
- Do not modify the equipment in any way. Unauthorised modification may impair the function and/or safety and could affect the life of the equipment and persons.
- Only use approved spare parts, and make sure they are only installed by authorised technicians.

2.3.4 Maintenance Safety

- Read and understand this manual, the operator manual of the milking robot and all safety signs before you connect the sampler to the milking robot.
- Only trained persons are permitted to operate the sampler and the milking robot.
- Make sure all covers and guards are installed when maintenance work is underway.

2.4 Safety Decals

2.4.1 Safety Decal Messages

General safety messages appear in this safety messages section. Specific safety messages are in applicable parts of this manual when potential hazards may occur if the instructions or procedures are not followed.

2.4.2 Maintenance of Safety Decals

- Safety symbols, labels and stickers on the sampler should be replaced if lost or illegible.

2.4.3 Installation of Safety Decals



Figure 2. Safety decal on the sampler

3 Specifications

3.1 Sampler 54 vials

Dimensions and weight	
Model	ARSD L 54
Length:	500 mm
Width:	470 mm (without carrying handle)
Height:	305 mm
Weight:	12 kg
Capacity	
Nr. of trays:	54
Nr. of bottles per tray:	54
Bottle capacity:	27,30,40 ml
Feed	
Compressed air	Max: 6 Bar, Min: 4 Bar

3.2 Sampler 60 vials

Dimensions and weight	
Model	ARSD L 60
Length:	450 mm
Width:	420 mm (without carrying handle)
Height:	305 mm
Weight:	10 kg
Capacity	
Nr. of trays:	60
Nr. of bottles per tray:	60
Bottle capacity:	27/ 30/ 40 ml
Feed	
Compressed air	Max: 6 Bar, Min: 4 Bar

3.3 Sampler 72 vials

Dimensions and weight	
Model	ARSD L 72
Length:	500 mm
Width:	470 mm (without carrying handle)
Height:	305 mm
Weight:	12 kg
Capacity	
Nr. of trays:	72
Nr. of bottles per tray:	72
Bottle capacity:	27/ 30/ 40 ml
Feed	
Compressed air	Max: 6 Bar, Min: 4 Bar

3.4 Sampler 80 vials

Dimensions and weight	
Model	ARSD LA 80
Length:	610 mm
Width:	600 mm (without carrying handle)
Height:	305 mm
Weight:	16 kg
Capacity	
Nr. of trays:	80
Nr. of bottles per tray:	80
Bottle capacity:	27,30,40 ml
Feed	
Compressed air	Max: 6 Bar, Min: 4 Bar

3.5 Sampler 90 vials

Dimensions and weight	
Model	ARSD L 90
Length:	500 mm
Width:	470 mm (without carrying handle)
Height:	305 mm
Weight:	12 kg
Capacity	
Nr. of trays:	90
Nr. of bottles per tray:	90
Bottle capacity:	27/ 30/ 40 ml
Feed	
Compressed air	Max: 6 Bar, Min: 4 Bar

3.6 Sampler 110 vials

Dimensions and weight	
Model	ARSD LA 110
Length:	610 mm
Width:	600 mm (without carrying handle)
Height:	305 mm
Weight:	16 kg
Capacity	
Nr. of trays:	110
Nr. of bottles per tray:	110
Bottle capacity:	27 ml/30ml/40ml
Feed	
Compressed air	Max: 6 Bar, Min: 4 Bar

3.7 Sampler 132 vials

Dimensions and weight	
Model	ARSD LA 132
Length:	610 mm
Width:	600 mm (without carrying handle)
Height:	305 mm
Weight:	16 kg
Capacity	
Nr. of trays:	132
Nr. of bottles per tray:	132
Bottle capacity:	27/ 30/ 40 ml
Feed	
Compressed air	Max: 6 Bar, Min: 4 Bar



4 Description and Operation

4.1 Description

This chapter describes the parts of the Sampler. It also explains how the parts work together to sampling.

The sampler is a rotating system in which the set of samples moves in order to maintain the filling system fixed. It is protected by a resistant aluminium case (1) which makes it light and easy to transport.

4.2 Component Description

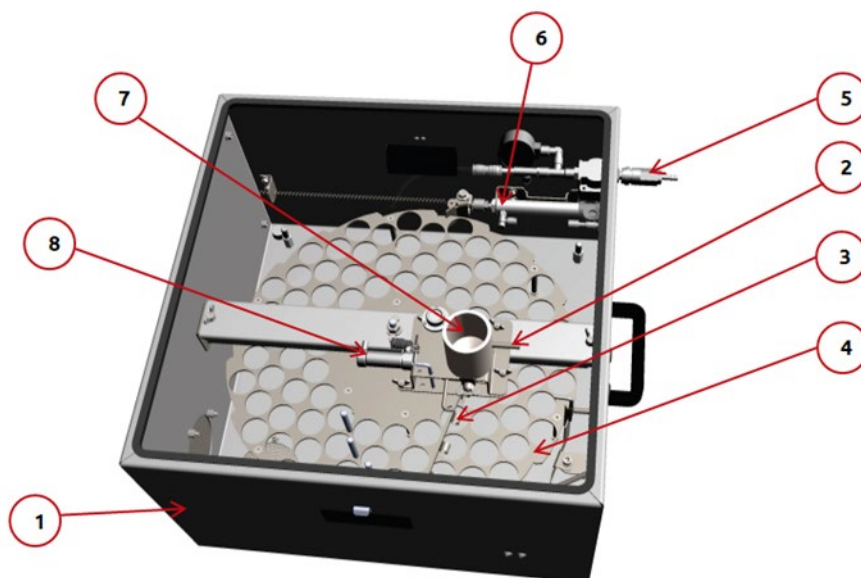

Figure 3. overview of the sampler

KEY:

1. Protective case - 2. Milk inlet - 3. Filling nozzle - 4. Drive crown and bottles support - 5. Compressed air hose inlet - 6. Cylinder for crown rotation - 7. Milk deposit - 8. Filling activating cylinder

4.3 How the sampler works

The sampler works by action of compressed air (5) and consists of a double crown (4); the upper part made of stainless steel, the bottles, and the lower part, which serves as support, are made of PVC. The upper part is a gearwheel, allowing it to move by means of a pneumatic cylinder (6). Milk (2) taken from the milking robot is sent to a calibrated milk deposit (7). The cylinder (8) is activated to carry out the filling of the bottle via the filling nozzle (3).

The numbers used refer to Figure 3

4.4 How the sampler changes to the next row

The sampler starts at position 1 and goes through the first row. When the sampler completes the first row, the filling nozzle comes into contact with the spindle and moves to the second row. For each spindle, the filling nozzle moves to the next row. The last pin moves the filling nozzle to the drain. See Figure 4.

	Rows	Number vials per row	Spindle (including drain)
Sampler 54 vials	3	18	3
Sampler 60 vials	4	15	4
Sampler 72 vials	4	18	4
Sampler 80 vials	4	20	4
Sampler 90 vials	5	18	5
Sampler 110 vials	5	22	5
Sampler 132 vials	6	22	6

Figure 4 . Table for each type of sampler

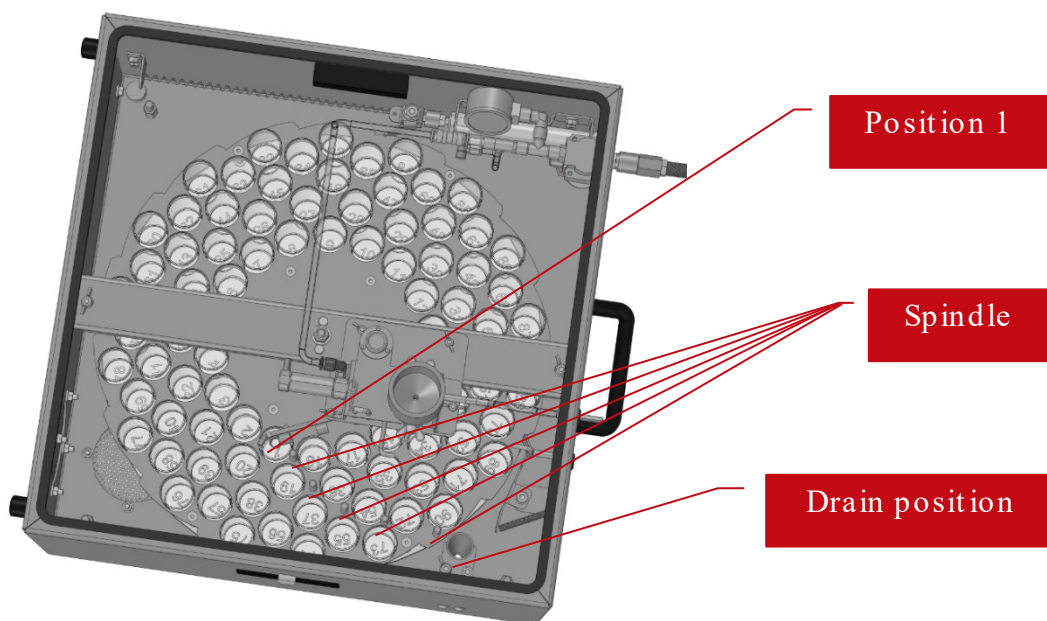

Figure 5. overview of the sampler with spindle

4.5 Operation

The system is controlled by the robot with the use of compressed air and transports the milk by gravity into the sampler. The system works in 5 stages:

	Sampler action	Robot action	
Step 1	Waiting for the sample	The robot milks the cow	See Figure 6
		During milking, the milk in the vessel is homogenised by the robot through the milk tube of the sampler	
		End of milking and other session of homogenisation	
Step 2	Receive the milk in the milk deposit	Robot sends the milk (open valve)	See Figure 7
Step 3	Sample calibration	Robot takes the milk in the milk deposit by vacuum	See Figure 8
Step 4	Filling the vial, and activating the cylinder for crown rotation	Robot activates the air pressure to the sampler	See Figure 9
Step 5	Moving the crown to the next sample	Robot deactivates the air pressure to the sampler when the next cow is being milked.	See Figure 10

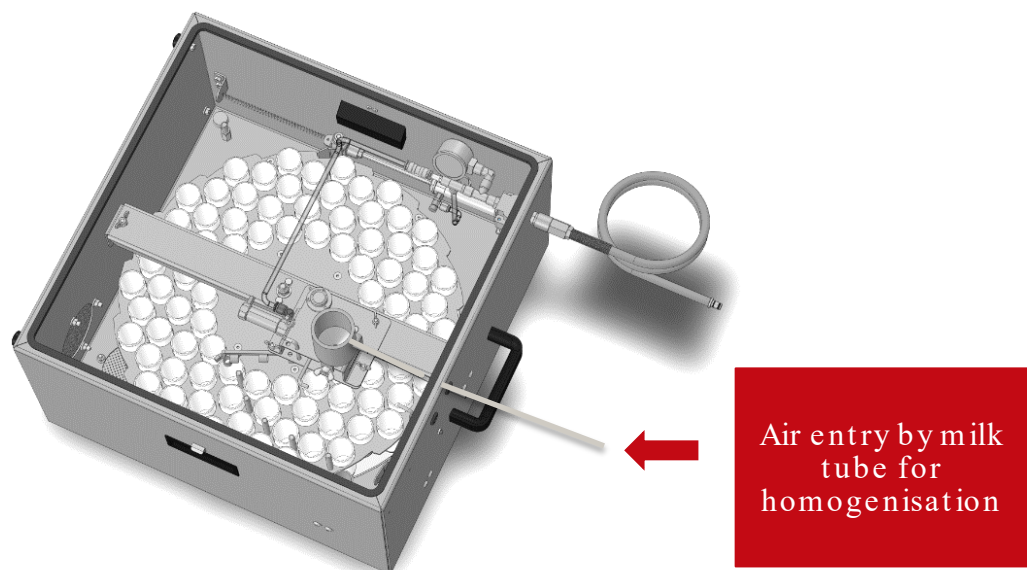

Figure 6. *Waiting for the sample*

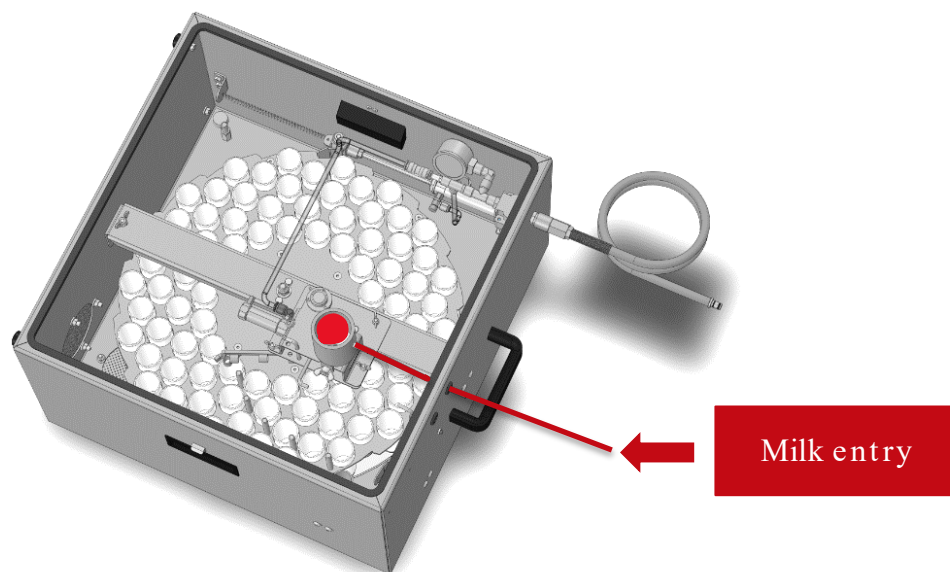

Figure 7. *Receive the milk in the milk deposit is important, to fill as much milk as possible in the milk deposit, and suck back the remaining amount*

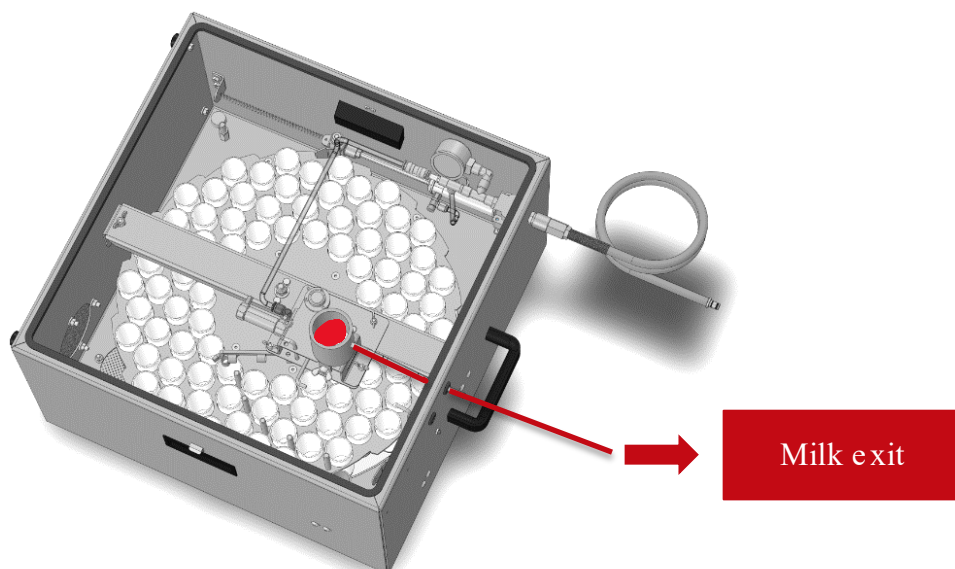

Figure 8. *Sample calibration*

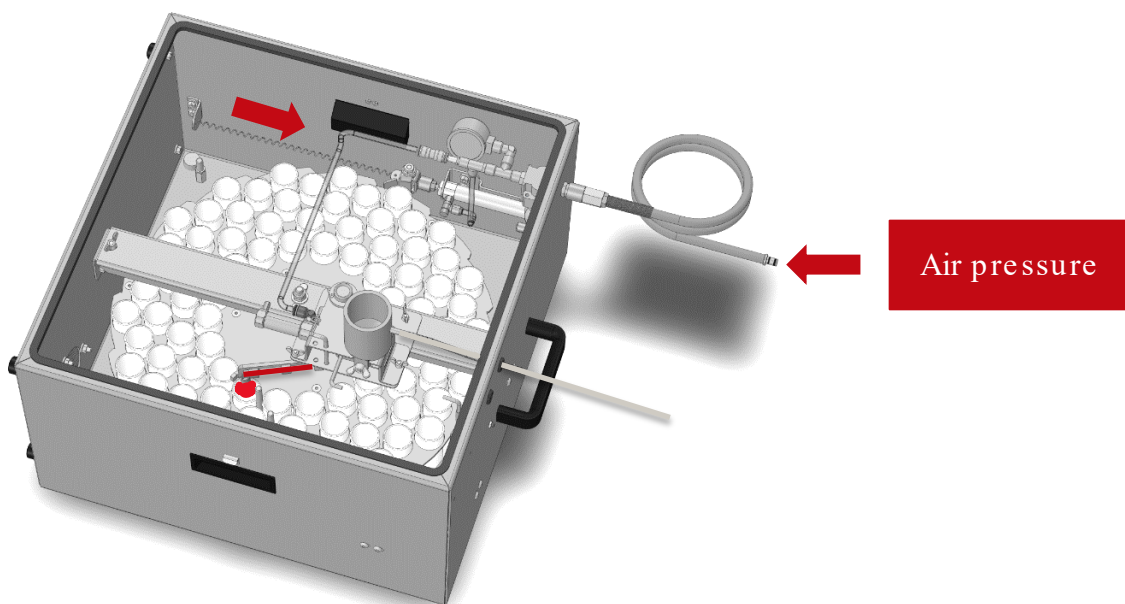

Figure 9. *Filling the vial, and activating the cylinder for crown rotation*

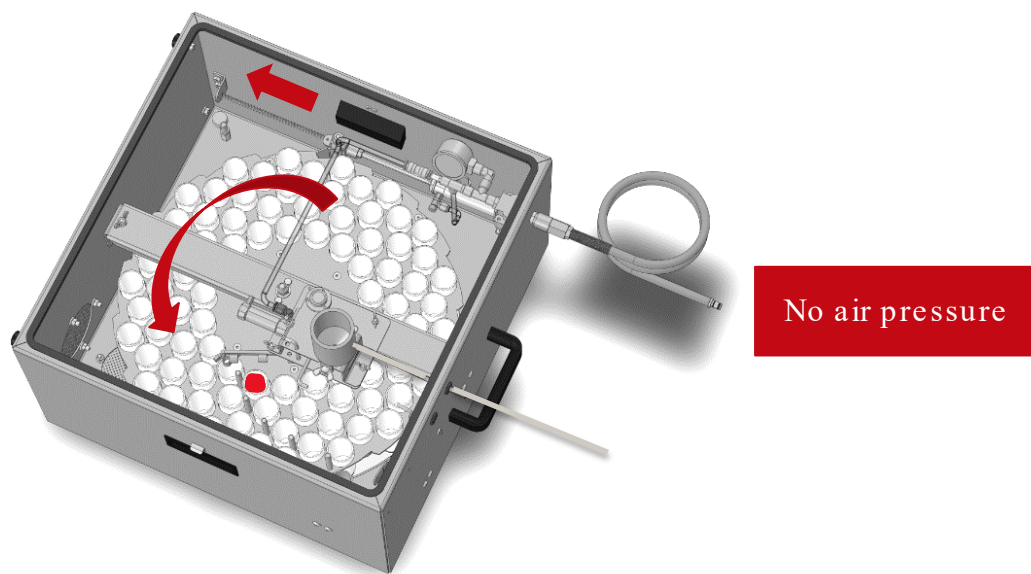

Figure 10. *Moving the crown for next sample*

5 Operating Instructions

5.1 Transporting the sampler.



Always lock the cover when carrying the sampler.



Do not transport the sampler with empty or filled sample bottles installed.

Make sure:

1. The milk tube is disconnected from the milk tube connection of the robot.
2. The air connection is disconnected from the air intake of the robot.
3. The cover is closed.
4. Lift the sampler using the transport handle (1). See the figure 11

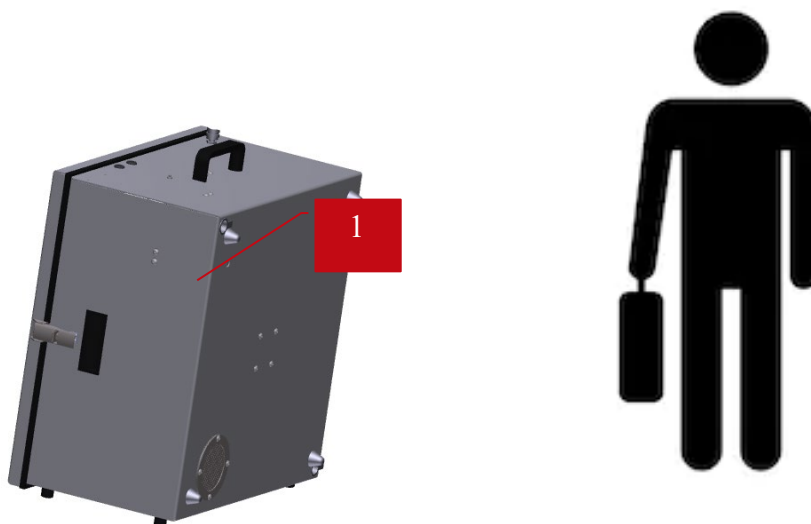

Figure 11. *Transporting the sampler*

5.2 Connecting the sampler.

5.2.1 Installing the sampler



- Make sure the sampler, the sampling bottles and milk tube are clean.
- Clean the sampler if it has not been used for more than three days.
- See Chapter 7 cleaning and maintenance.
- Make sure the robot arm cannot hit you when you work on the sampler.
- Make sure the robot arm cannot hit the sampler.
- The sampler must be installed in a lower position than the milk jar.
- The top of the sampler must be below the 5 kg level.
- The sampler will be installed very close to the vessel.

1. Position the sampler in the vicinity of the milking robot.
2. Make sure the 5 kg level of the milk jar is at least 36 cm (14.2”) above the floor level of the sampler.
3. Loosen the fasteners and open the cover of the sampler. Level the sampler by unscrewing the feet in using the level bubble of the main bracket. See the figure 12
4. Remove the lever to pinch the tube. See the figure 13
5. Load the crown with the vials, removing the cap first. See the figure 14: It is important to add a label or identify properly the vials to avoid errors when transferring to the carrying box.

The content of the sample box contains poisonous substances necessary to preserve the milk samples. There is a danger of damage to health if:



- large quantities of the preservative are inhaled;
- the preservative comes into contact with the skin;
- the preservative is swallowed.

7. If the cap is attached, put it in the space of the crown with the lid of each vial at an angle of 90°.



Do not use vials which are not flat or are bent.

8. Remove the lever to activate the crown's anti -reverse system. See the figure 15
9. Place the bracket to fill the vial in the right position (number 1) . See the figure 16
10. Connect the milk tube to the milk deposit, and use the hole to pass the milk tube outside . See the figure 17



Replace the cover to avoid any water or milk entering the sampler.
Always lock the cover when sample bottles are in the sampler.

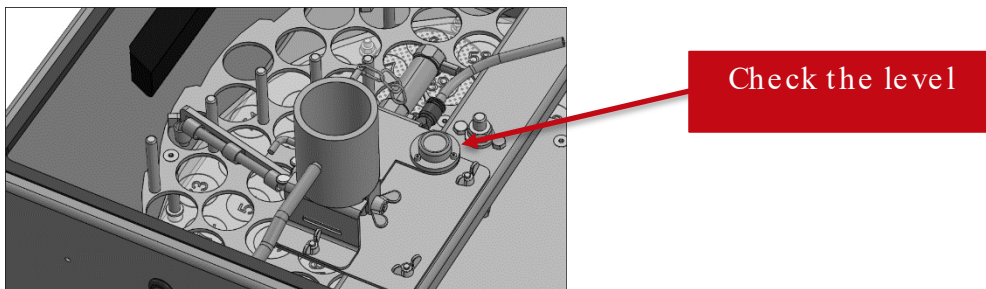

Figure 12. Level the Sampler

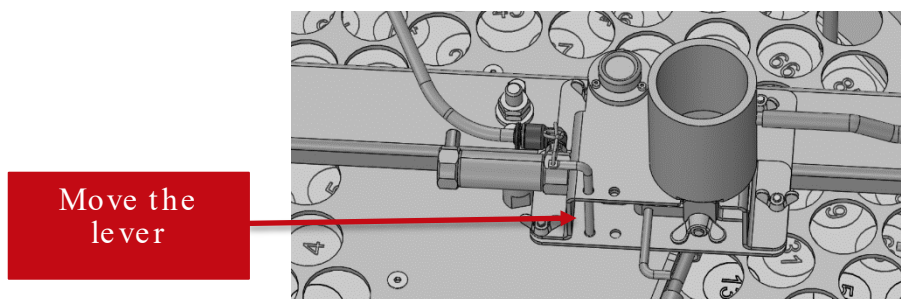

Figure 13. Remove the lever and insert it in the second position



Figure 14. Overview with all the vials in the sampler



Figure 15. Activate the crown's anti-reverse system

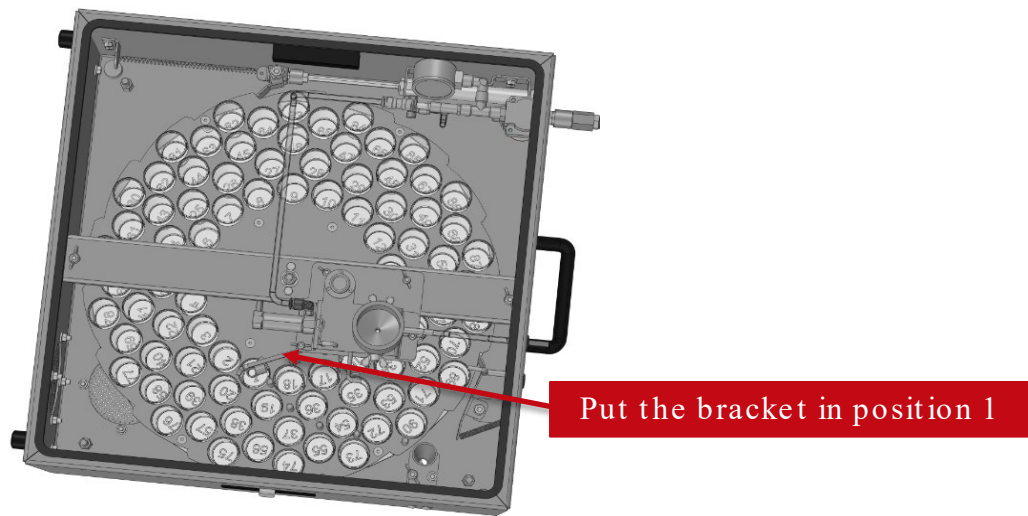

Figure 16. Put the bracket to fill the vial in the right position (number 1)

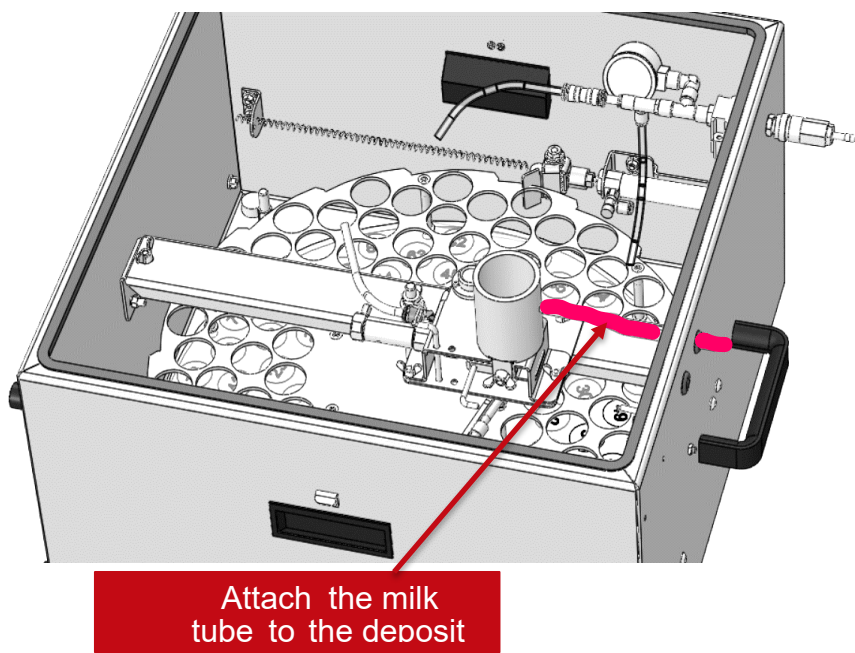

Figure 17. Attach the milk tube and pass it through the hole

5.2.2 Setting the robot for the sampler.



Before connecting the sampler to the Robot, put the robot in Pause or OUT of OPERATION mode.

In the console X-Link

1. Put the robot in Pause mode, see the figure 18
2. In the Menu Settings, select Milk procedure, Milk sampling, see the figure 19
3. In the Menu Settings, select Milk sampling, Rack Type, see the figure 20
4. In the Menu Settings, select Milk sampling, Rack Type, Rotary Shuttle and Save, see the figure 21
5. Adjust all the settings for the sampler, see the figure 22 and 23
6. Close the settings.



Figure 18. Robot in Pause screen

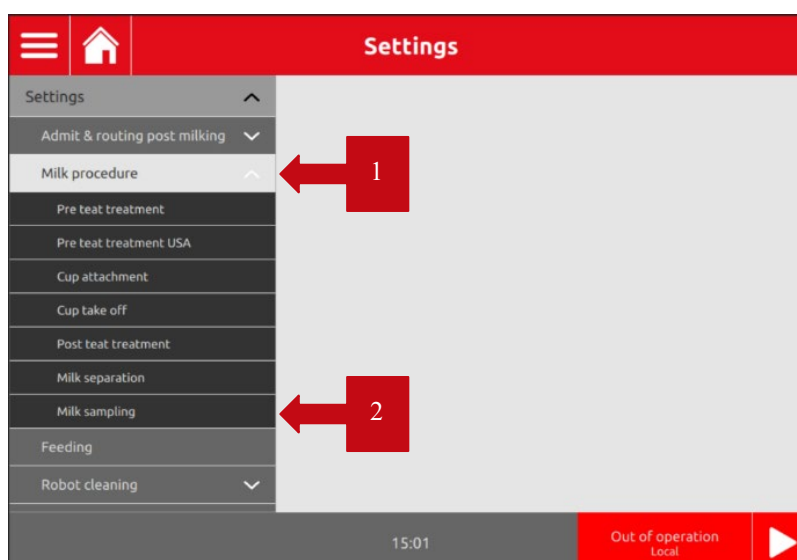

Figure 19. Menu Settings, Milk procedure, Milk sampling

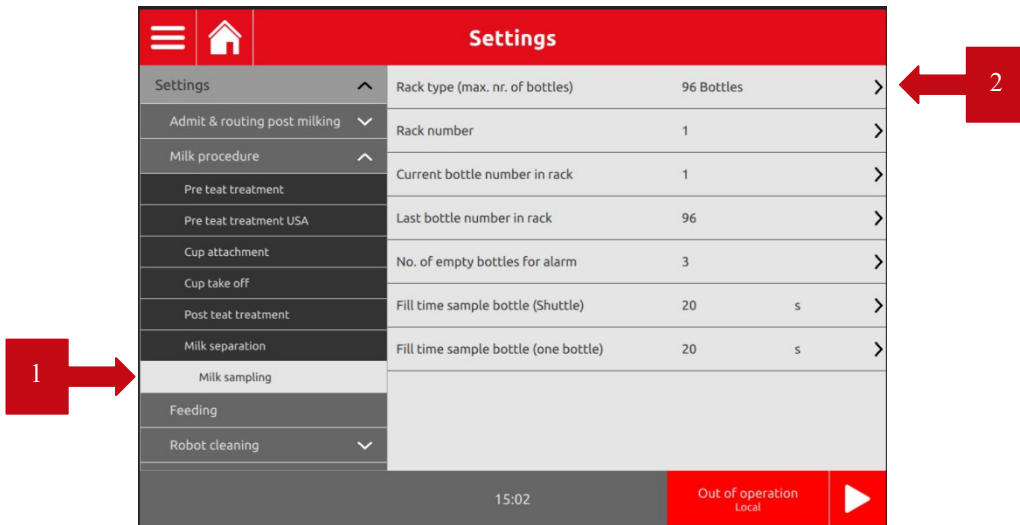

Figure 20. Menu Setting Milk sampling, Rack Type

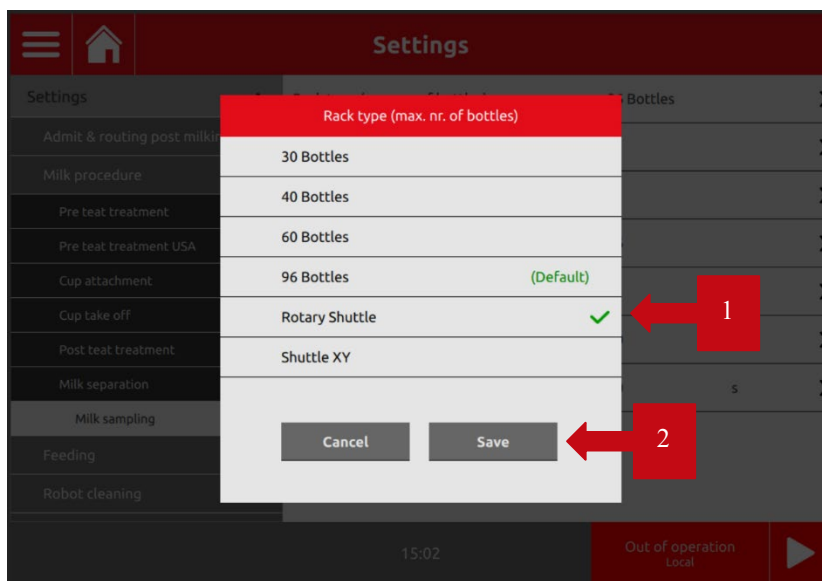

Figure 21. Menu Setting Milk sampling, Rack Type, Rotary Shuttle and Save

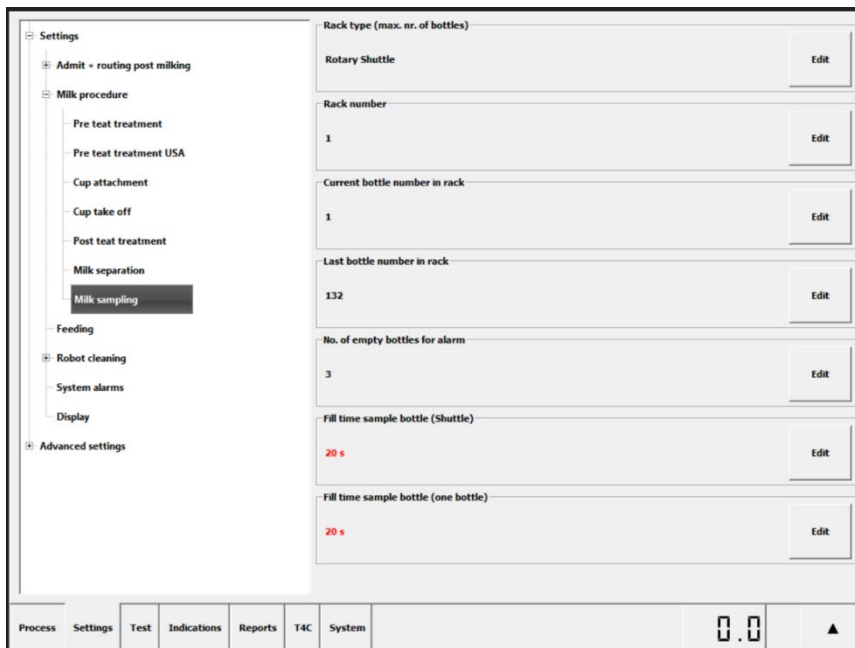

Figure 22. Menu setting for the sampler only for A3 and A4

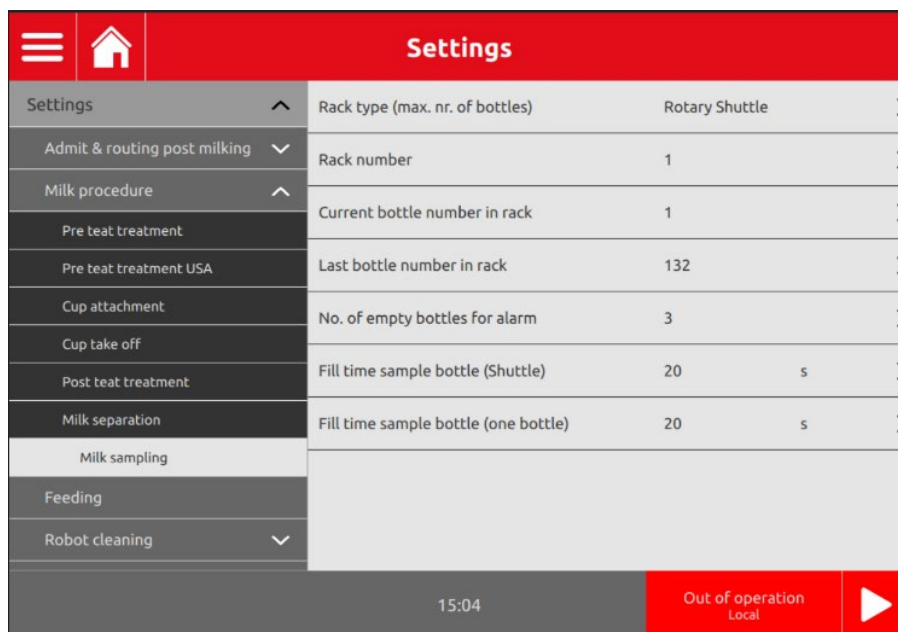

Figure 23. Menu setting for the sampler only for A 5

5.2.3 Connecting the milk tube sampler to the milk jar

In the console X -Link

Note: the screens in the following pictures are based on the A5 User Interface

1. In the All Actions menu, select Start milk sampling, see the figure 24
2. Select Start milk sampling , see the figure 25
3. On the Menu, Click Open, see the figure 26
4. Connect the milk tube to the pipe.
 - To connect the milk tube to an Astronaut A2 or A3 milking robot, pass the milk tube through hole 1, remove nipple 3, put nipple 4 and connect the milk tube to nipple 4, see the figure 27
 - To connect the milk tube to an Astronaut A3 Next milking robot, pass the milk tube through hole 2, remove stop nipple 5, put nipple 6 and connect the milk tube to nipple 6, see the figure 28
 - Connect the milk tube to an Astronaut A4 milking robot, pass the milk tube 5 through the hole for sampling cylinder 6, remove stop nipple 2 and connect the milk tube 3 to the nipple on the elbow 1, see the figure 29
 - Connect the milk tube to an Astronaut A5 milking robot; pass the milk tube through hole, remove stop nipple 2, put the nipple and connect the milk tube 3 to the elbow 1, or base under receiver see the figure 30 and 30.1
5. In the menu Milk sampling, Click on Close and Next, see the figure 31
6. View of settings, click on Next, see the figure 32
7. The session is ready for sampling. Click on the cross, see the figure 33

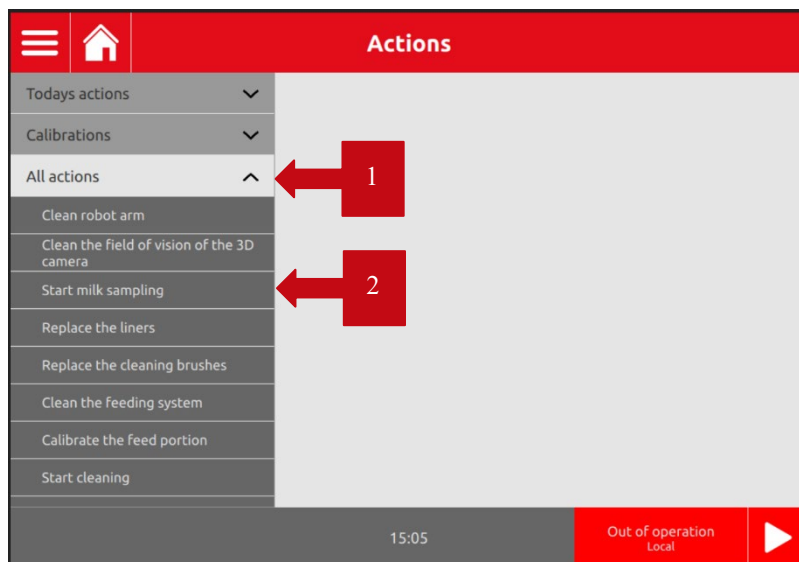

Figure 24. Menu All Actions, Start milk sampling

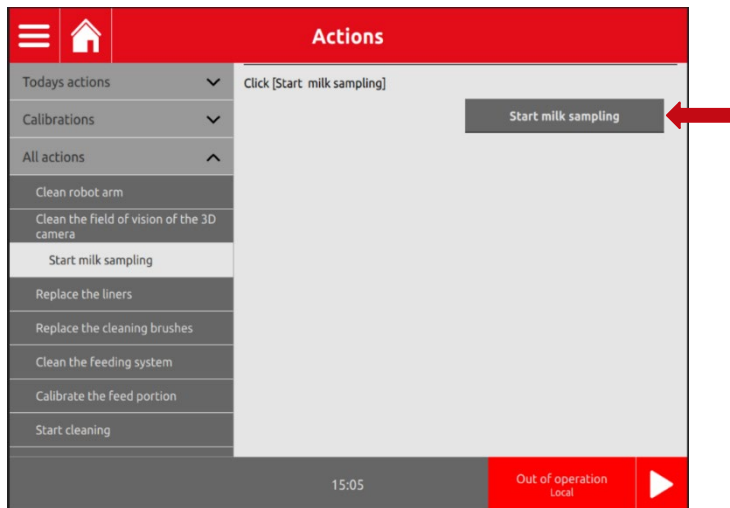

Figure 25. Menu Start milk sampling

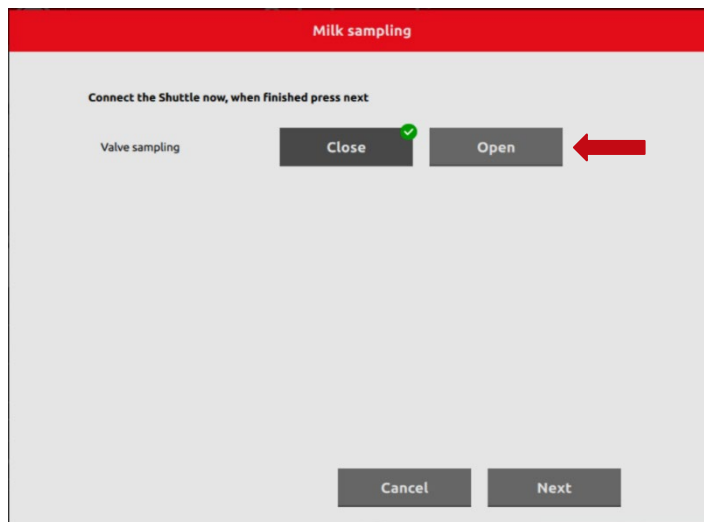

Figure 26. Milk sampling menu

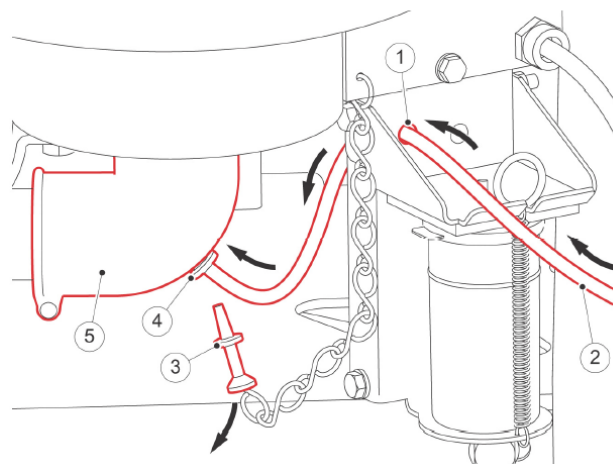

Figure 27. For the Astronaut A3 milking robot.

Key:- 1. Sampling Cylinder 2. Milk Tube \varnothing 1,5 mm and 1.000 mm length 3. Plug – 4 Nipple - 5. Elbow

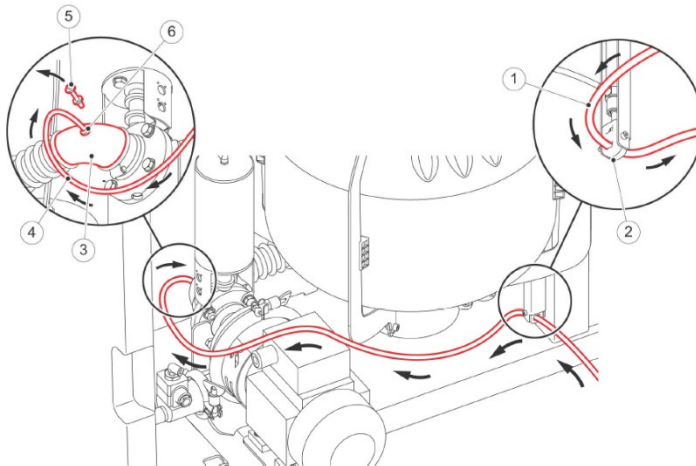

Figure 28. For the Astronaut A3 Next milking robot

Key: 1. Milk Tube 4x1,5 mm and 1.000 mm length 2. Sampling Cylinder 3. Elbow - 4 Milk Tube - 5. Plug - 6. Nipple

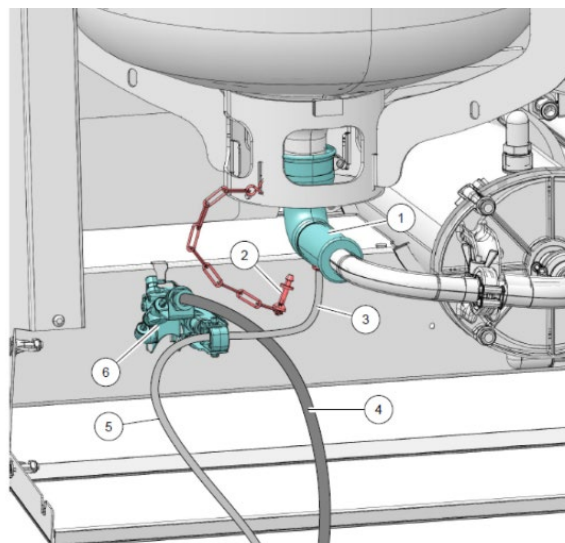

Figure 29. For the Astronaut A4 milking robot

Key: 1: Elbow - 2. Plug - 3 Nipple - 4 Tube (compressed air to sampler) - 5. Milk tube 4x1,5 mm 1000 mm length - 6. Sampling Cylinder

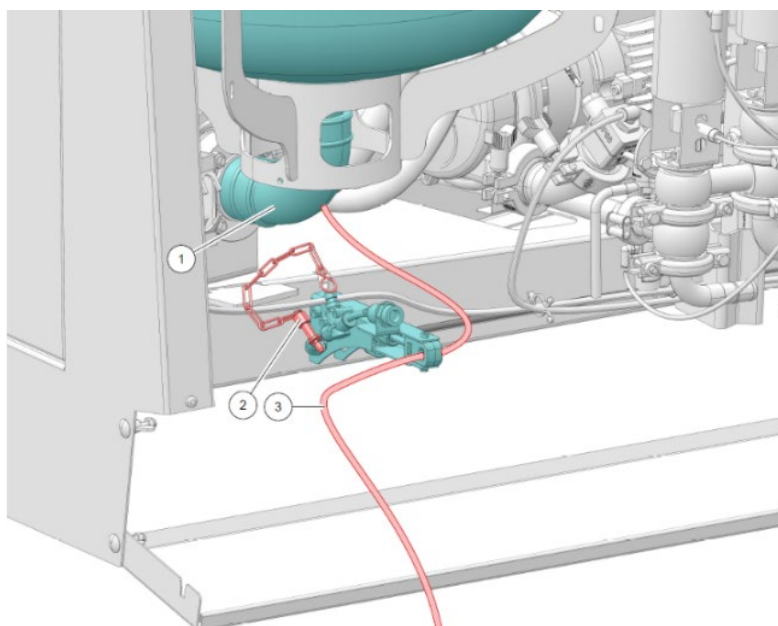

Figure 30. For the Astronaut A5 milking robot , version 1

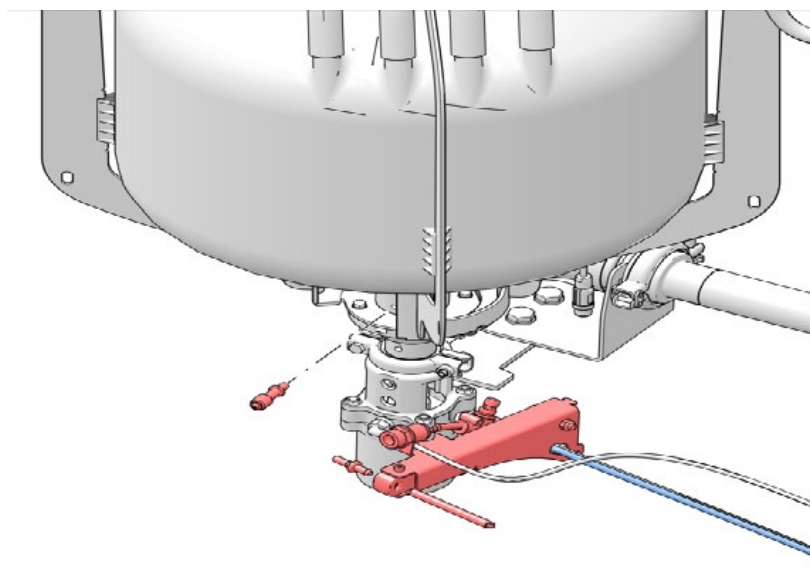

Figure 30.1 For the Astronaut A5 milking robot, version 2

Key: 1. Elbow-2. Plug-3. Milk tube 4x1,5 mm and 1.000 mm length

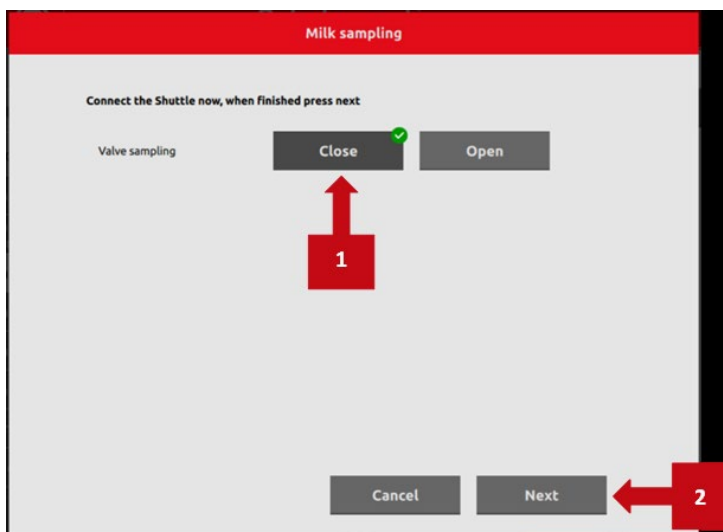

Figure 31. Milk sampling menu

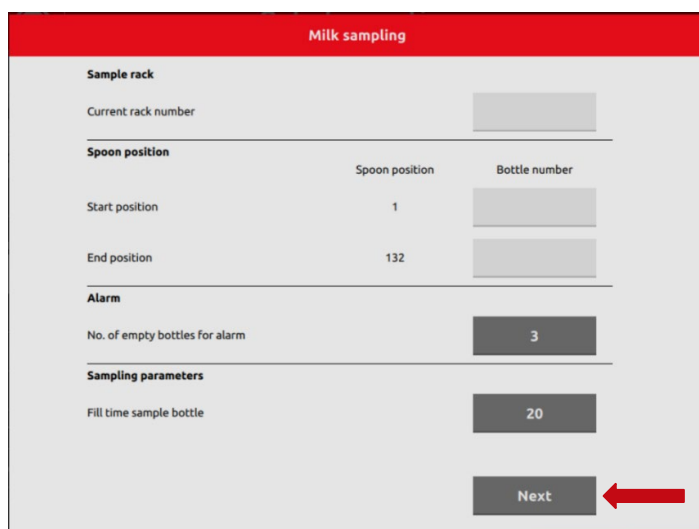

Figure 32. Milk sampling menu

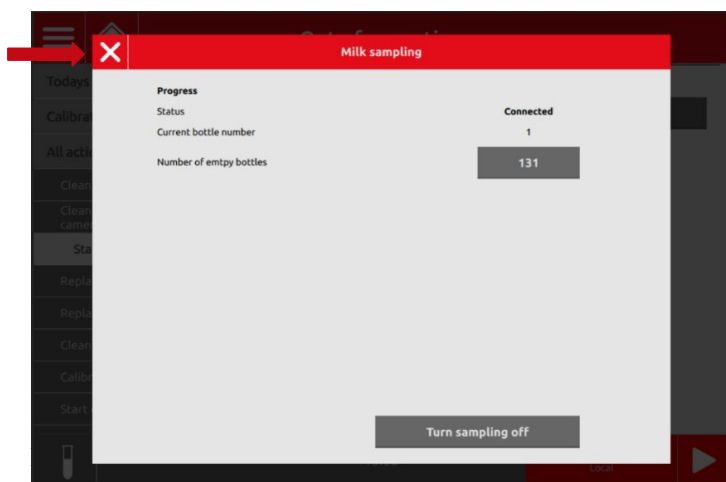

Figure 33. Milk sampling menu



5.2.4 Connect the air pressure between the sampler and the Robot

1. Connect the air tube to the sampler , see figure 34
2. Connect the air connector to the robot.
 - Connection for Astronaut A3, see figure 35
 - Connection for Astronaut A3Next and A4, see figure 36
 - Connection for Astronaut A4, see figure 37
 - Connection for Astronaut A5, version elbow and valve see figure 38 and 38.1

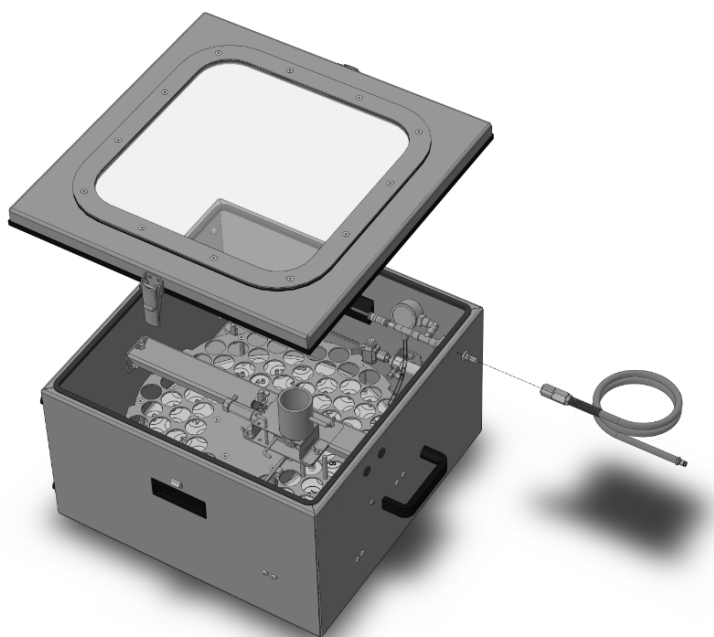

Figure 34. Air tube for sampler

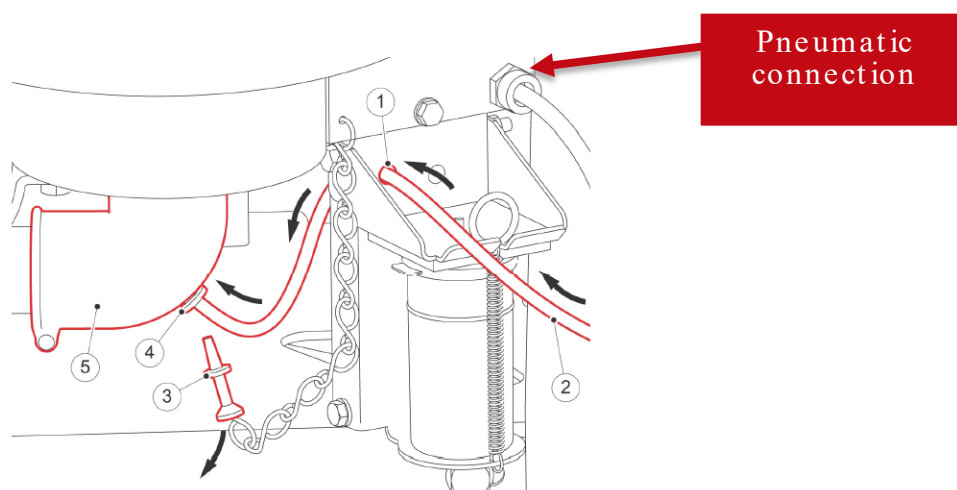

Figure 35. For Astronaut A3.

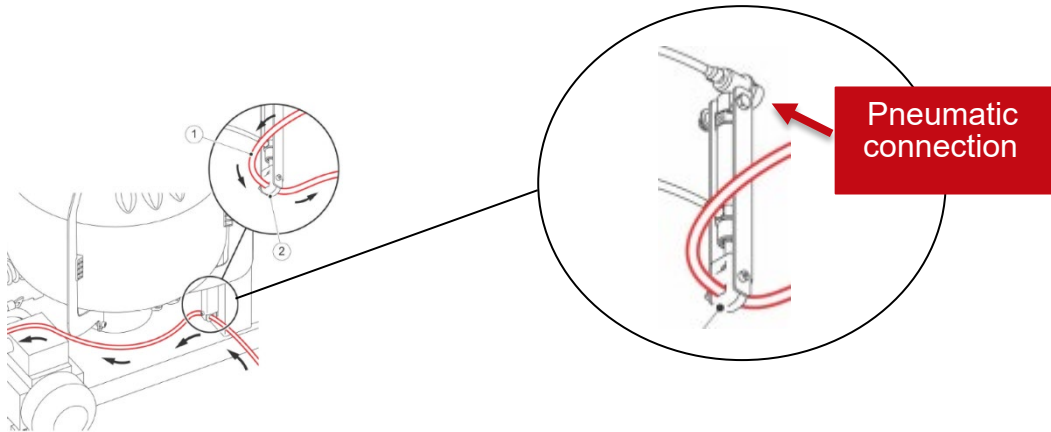

Figure 36. For Astronaut A3 Next

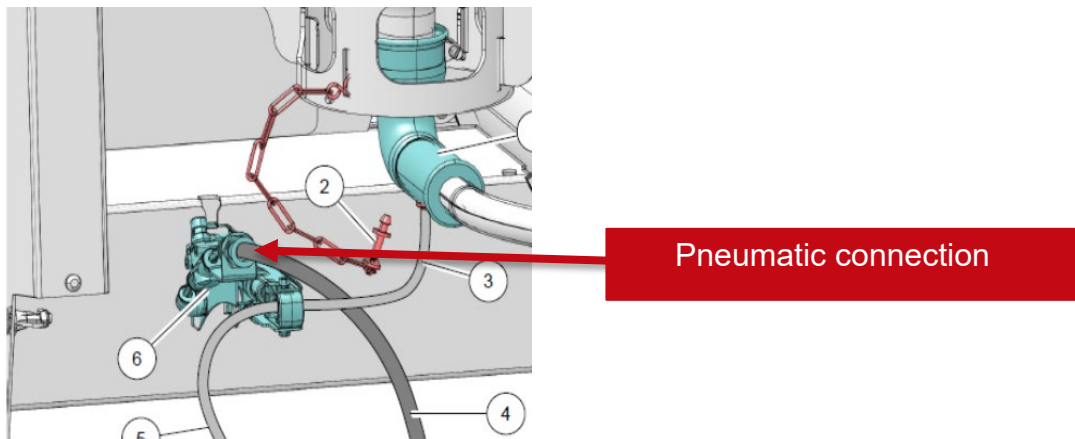
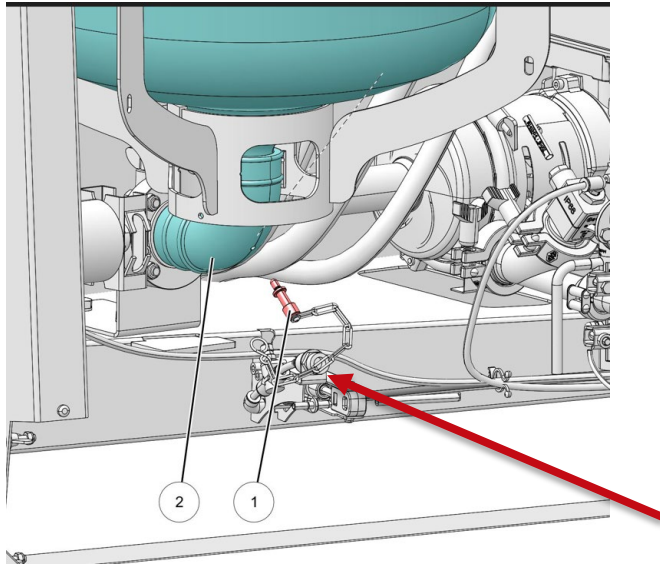
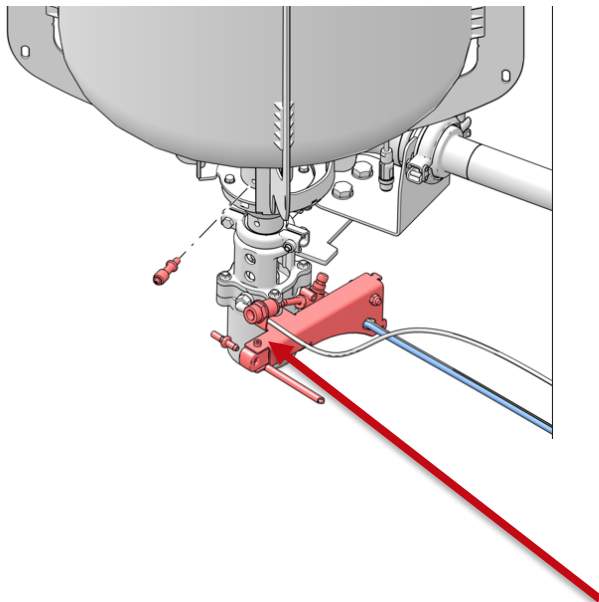

Figure 37. For Astronaut A4



Pneumatic connection

Figure 38. For Astronaut A5, version elbow



Pneumatic connection

Figure 38.1 For Astronaut A5 version valve

5.2.5 Starting the session milk sampling

1. On the menu Out of Operation, click on the arrow to start the robot.



This sample indicates that the milk sampling session is active.
See figure 39

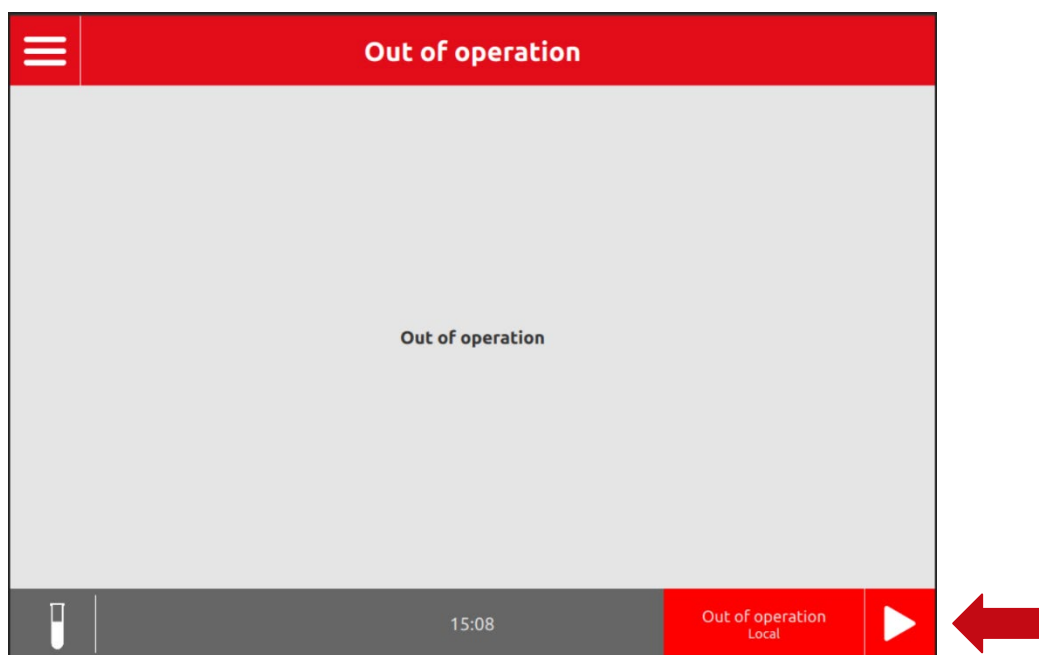



Figure 39. Out of operation menu

5.3 Closing the milk sampling session

At the end of the session, the milk tube and air pressure must be disconnected.

1. Put the robot into Pause or Out of Operation mode
2. On the screen E-Link, click on the  sample
3. On the Menu, select Turn sampling off, see the figure 40
4. On the Milk sampling menu, click on Open, see the figure 41
5. Remove the nipple on the jar, and remove it from the milk tube
6. Put on the stop nipple
7. Remove the milk tube through the hole
8. On the Milk Sampling menu, click on Close and next, see the figure 42
9. Remove the air pressure connector on the robot
10. Restart the robot and put in Operation mode with the Xlink

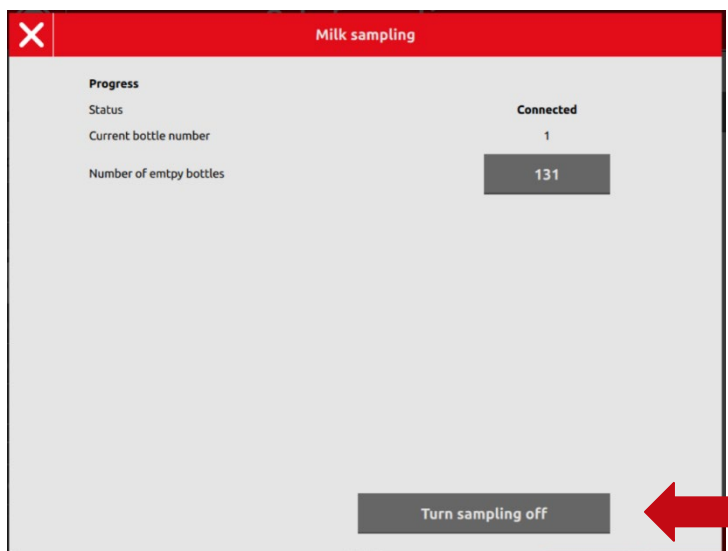

Figure 40. Milk sampling menu

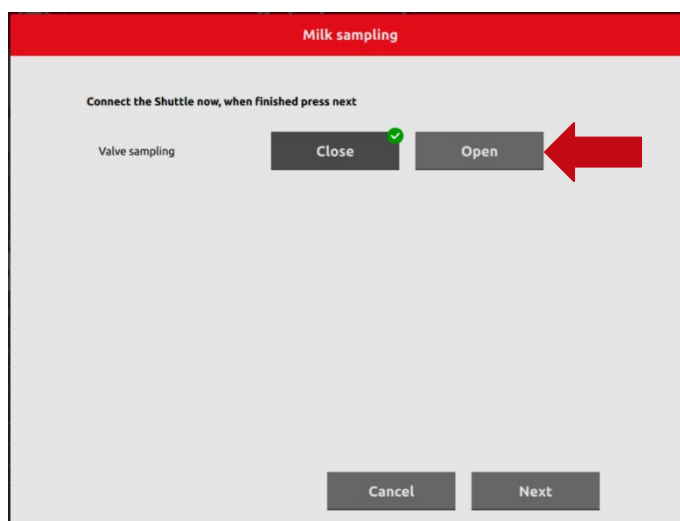

Figure 41. Milk sampling menu

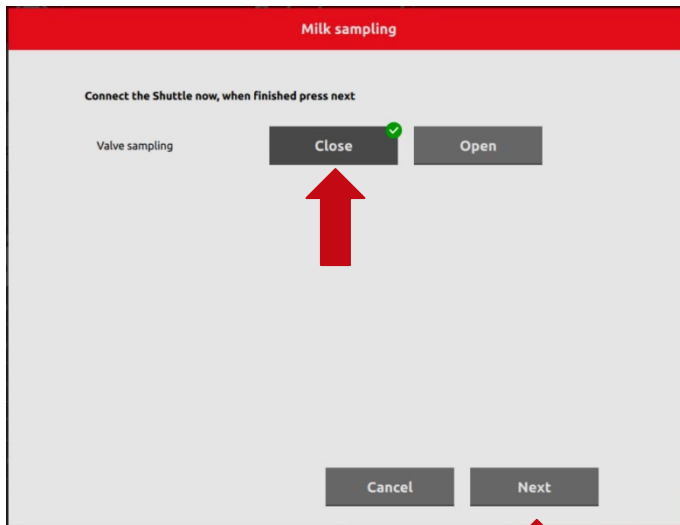

Figure 42. Milk sampling menu

5.4 Take the vials and clean the sampler

1. Take vial number 1 and put it in the rack position number 1. Repeat this operation for each vial and respect the numbering position in the rack. For each vial, the position is engraved on the crown. (Normally the position of the vial is written on the body of the vial)
2. Clean the sampler, the milk tube, and the nipple with soapy water. See figure 46
3. Clean the sampler, the milk tube, and the nipple with soapy water.

SUCCESS OF SAMPLING IS BASED IN THE CORRECT TRANSFER OF SAMPLES TO THE TRANSPORT RACK: PLEASE, ENSURE THAT BOTTLES ARE POSITIONED IN THE RIGHT PLACE. WHEN ONE VIAL IS MISPOSITIONED THE WHOLE SAMPLING DATA CAN BE WRONG.

5.5 Print the list of sample details

5.5.1 For the software T4C

1. In the navigation bar, select 'Data Exchange'
2. Select 'Milk Sampling Export'
3. Choose the export type of the required country.
4. Define the number of days (normally 30)
5. Click to export the report
6. Select the destination for the file (disc or memory stick)
7. Confirm the name of the file or change

5.5.2 For the software Horizon

1. Click on Manage in the left bar, see figure 43
2. Then click on Milk sampling export see figure 44
3. Choose the export type of the required country see figure 45
4. Define the number of days (normally 30) see figure 46
5. Click to export the report see figure 46
6. Select the destination for the file (disc or memory stick)
7. Confirm the name of the file or change

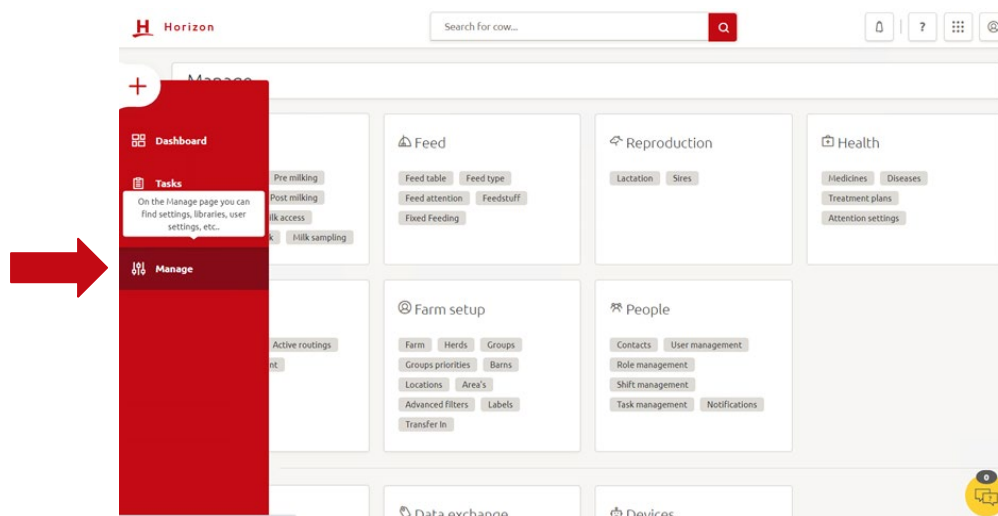

Figure 43. Select Manage



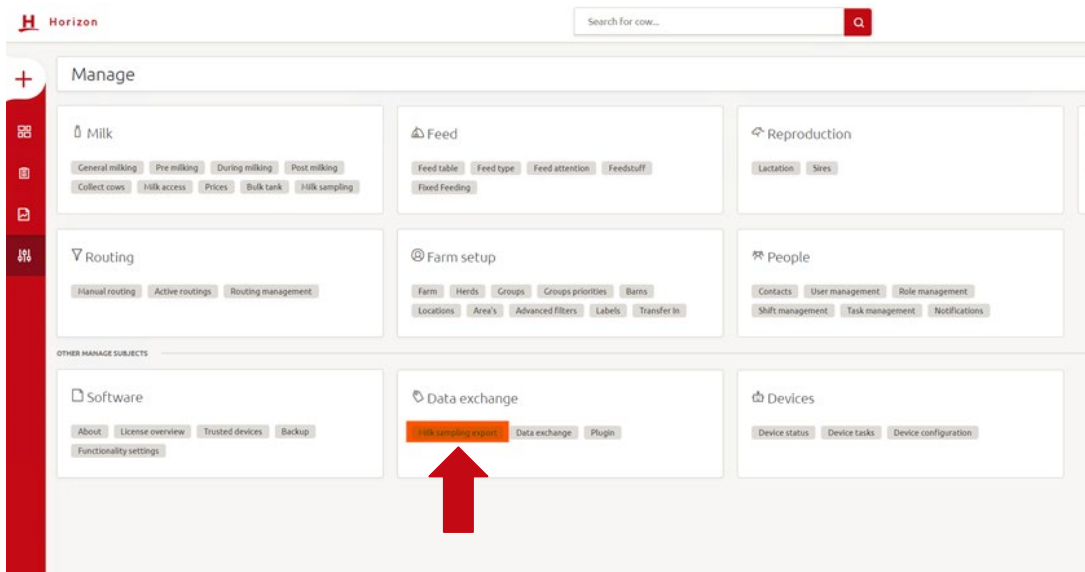

Figure 44. Select Milk sampling export

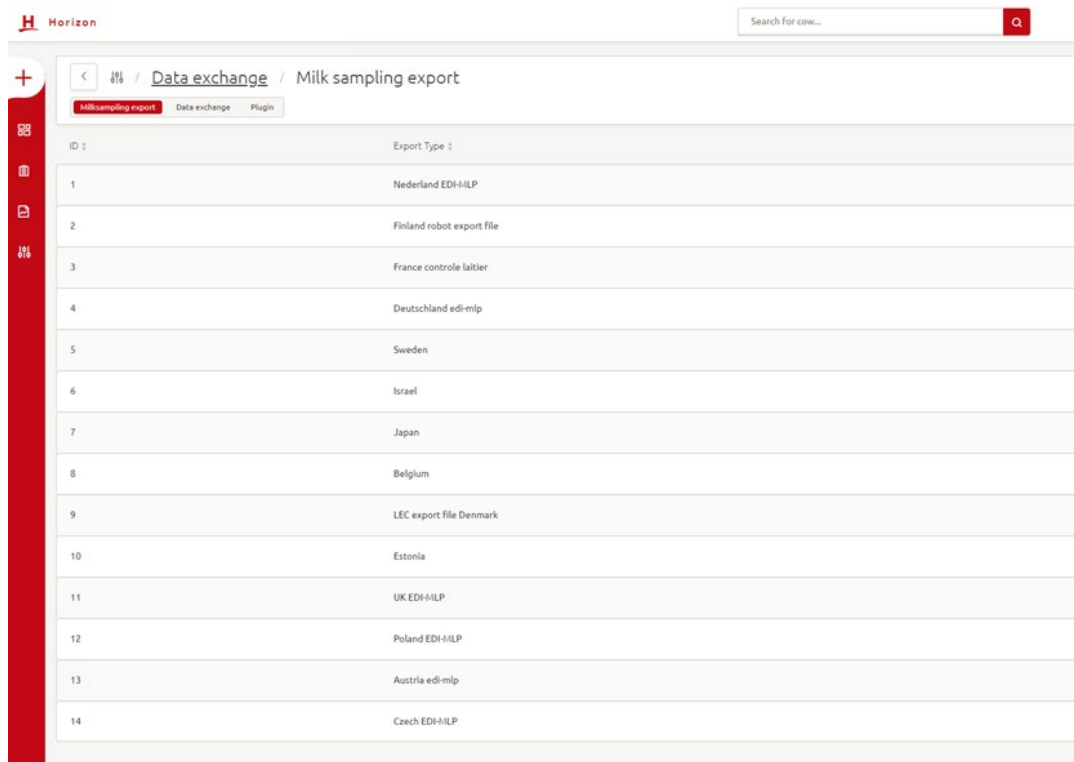

Figure 45. Select the export type of the required country

Export Options ✕

DAYSBACK

Farmer's e-mail

Dairy Company e-mail

[Cancel](#)

Figure 46. Export details

6 Installation

6.1 Introduction

The installation process of the sampler has the following phases:

- Prepare the installation.
- Install the sampler.
- Set up the sampler.

The installation is done by a Lely certified technician.

6.2 Preparation

6.2.1 Preparation by the Owner

Before the actual installation can start, several tasks should be done by the owner of the sampler with support from the Lely service provider. These tasks are most of the construction tasks for the farm and the purchase of equipment necessary to use the sampler:

- Check the vials used in the crown and the vial capacity.

6.2.2 Preparation by the Lely Service Provider

The Lely service provider can:

- Set the configuration for the sampler.
- Check the connection for air pressure and test the system.
- Test milk connection with the sampler
- Test the routine of the sampler for some cows.

6.2.3 List of supplied parts

The following parts are delivered:

- Full sampler box with cover
- Silicone milk tube and nipple
- Air pressure connection to connect sampler and robot.
- Manual and quality certificate

7 Cleaning and maintenance

7.1 Cleaning the filling system

7.1.1 Unmounting the filling system

- Before starting the cleaning process, make sure to put the pin of the filling system back in its locking position (Transport/off mode)
- Once the pin has been inserted in Transport/Off mode, the filling system may be disassembled to proceed with cleaning.

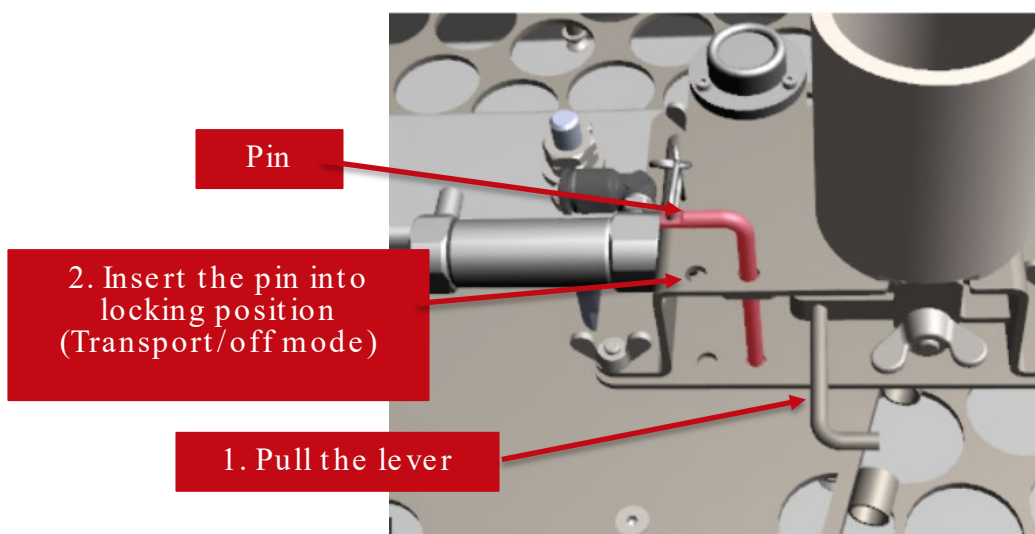

Figure 47. Pin in off or transport position

7.1.2 Removing the air tube

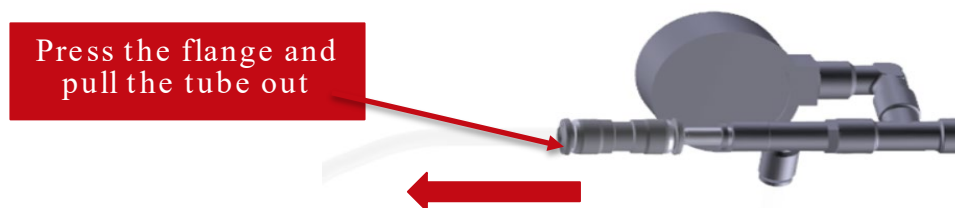

Figure 48. Disconnect the air tube

7.1.3 Disassembly of the milk deposit assembly

- Remove the 2 nuts.

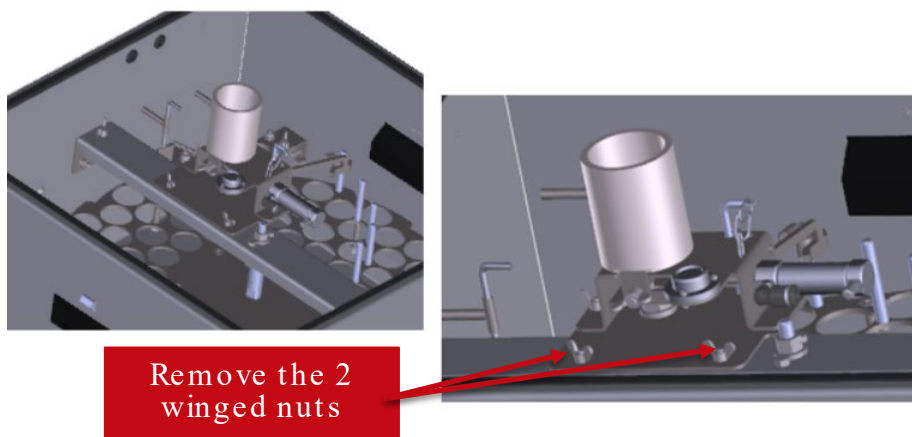

Figure 49. Remove the milk deposit assembly

The protecting case of the sampler may be cleaned with water. However, you must not:



- Overflow it with water.
- Spray the drive cylinder (it affects durability)
- Use pressure for cleaning (a simple damp cloth is necessary)



You must drain the remaining water through the designed evacuation points.

7.1.4 Cleaning the filling system and hoses

- The support can be removed so that it can be washed directly over a sink
- Use a syringe to inject a mix of hot water and some acid through the silicone hoses and the stainless-steel milk deposit.

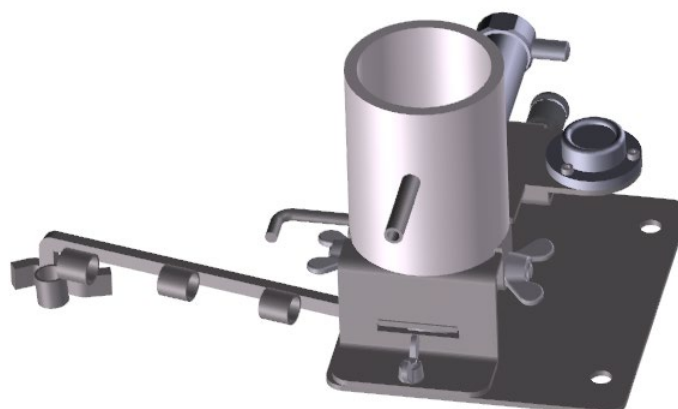

Figure 50. Clean the milk deposit



Since a chemical product is being used, protective personal equipment must be worn.

7.1.5 Cleaning the protecting case and crown

- The crown may be washed with water.

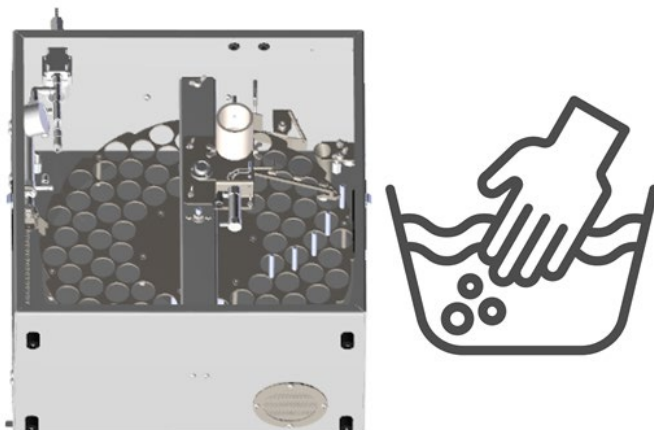

Figure 51. Clean the crown



Do not use pressure as this could damage the cylinders

7.1.6 Removing the silicone hose from the filling system

- Dismantle the stainless steel tank.
- Follow these steps to replace the silicone hoses:

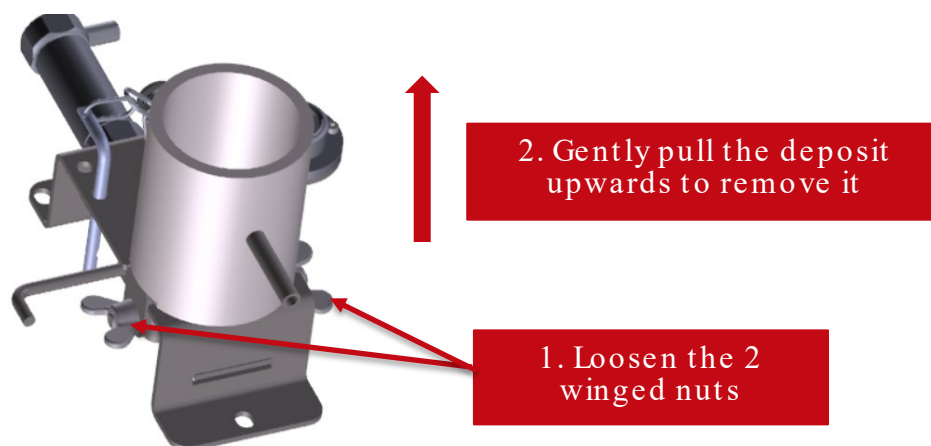

Figure 52. Remove the milk deposit

7.1.7 Removing silicone tube from the milk deposit

- Once the milk deposit has been removed, the silicone hose may be changed if it is damaged.

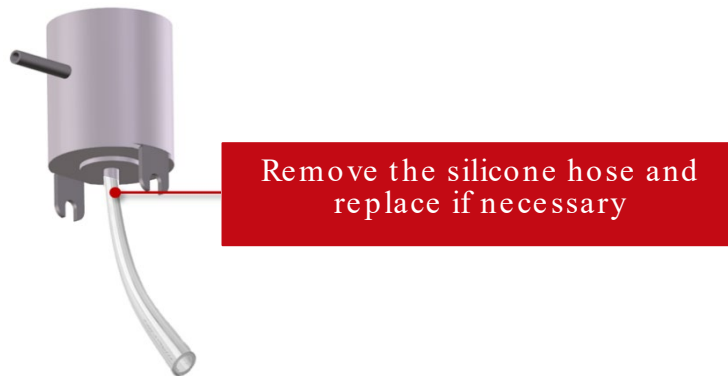

Figure 53. Remove the silicone

i Do not use silicone lubricant when replacing those as this could cause the hose to come off during operation.

7.1.8 Recommendation for fitting the silicon tube

- Before re-connecting the silicone milk line into the milk deposit, it must be lubricated with food grease as shown

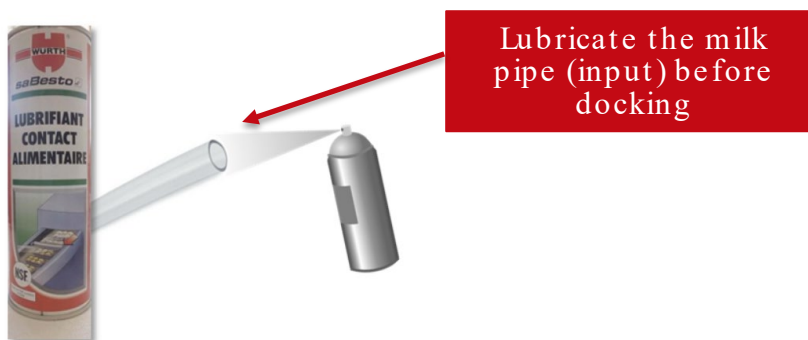

Figure 54. Lubrication with food grade silicone grease

7.1.9 Mounting the filling system

*Make sure the milk deposit input is facing the correct direction
Set the wing nuts back in place
Mount the milk deposit back in the support plate and onto the rail using the wing nuts.*

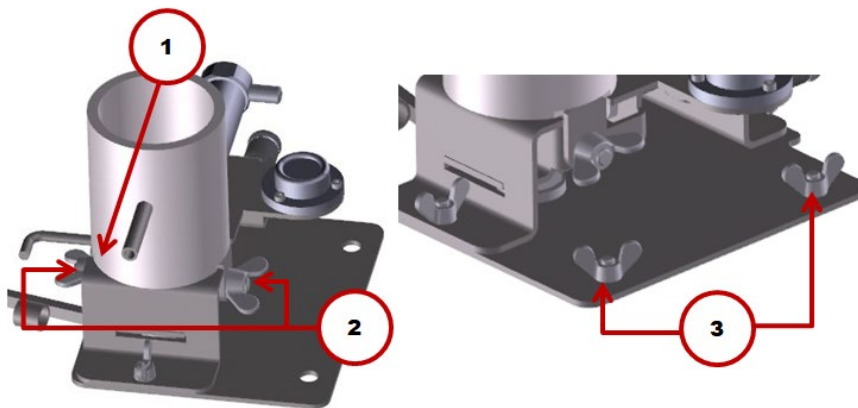

Figure 55. Assembly of milk deposit

7.1.10 Reconnecting the air tube

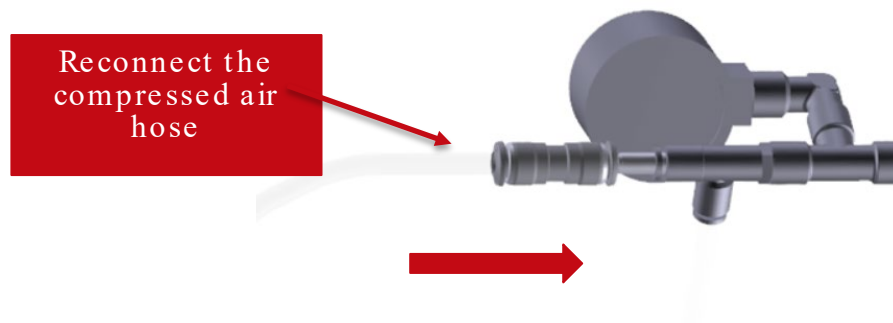

Figure 56. Re-connect air tube

7.2 Maintenance of the stainless steel crown



Before proceeding to dismantle the crown, please make sure the system is not connected to the compressed air

7.2.1 Disassembling the crown

- To facilitate maintenance, the drive system of the stainless steel crown may be removed.
- Disable the crown brake (1) by pushing it backwards (2) and locking it using the blocking pin (3)

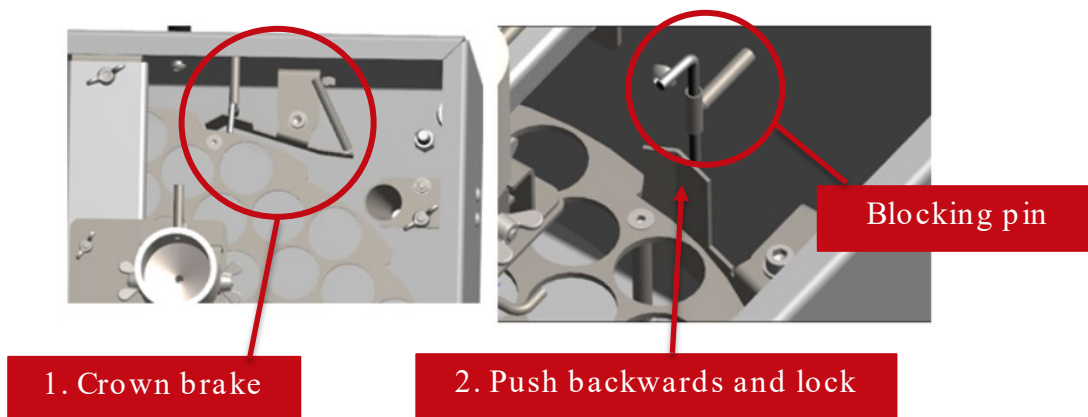

Figure 57. Disable the crown brake

7.2.2 Detach the crown from the case

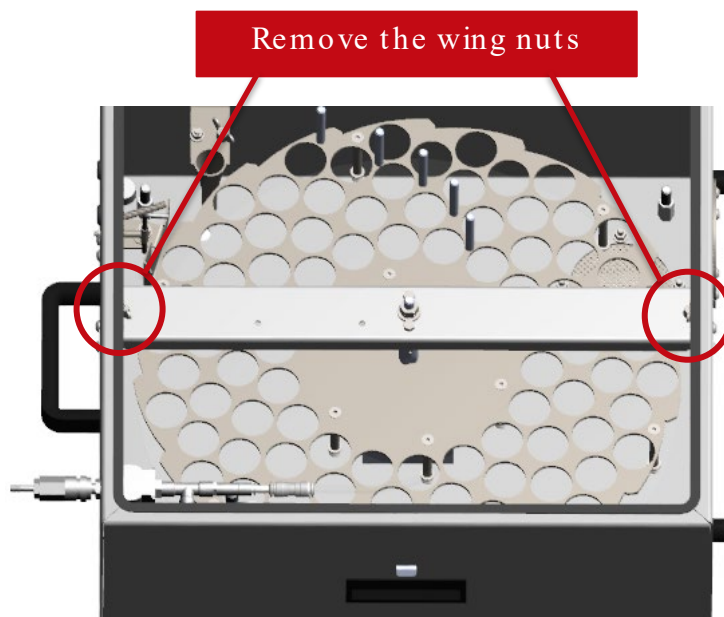

Figure 58. Disable the crown

7.2.3 Removing the crown from the case

Remove the crown by rotating and tilting it so that it clears through the wider space of the case

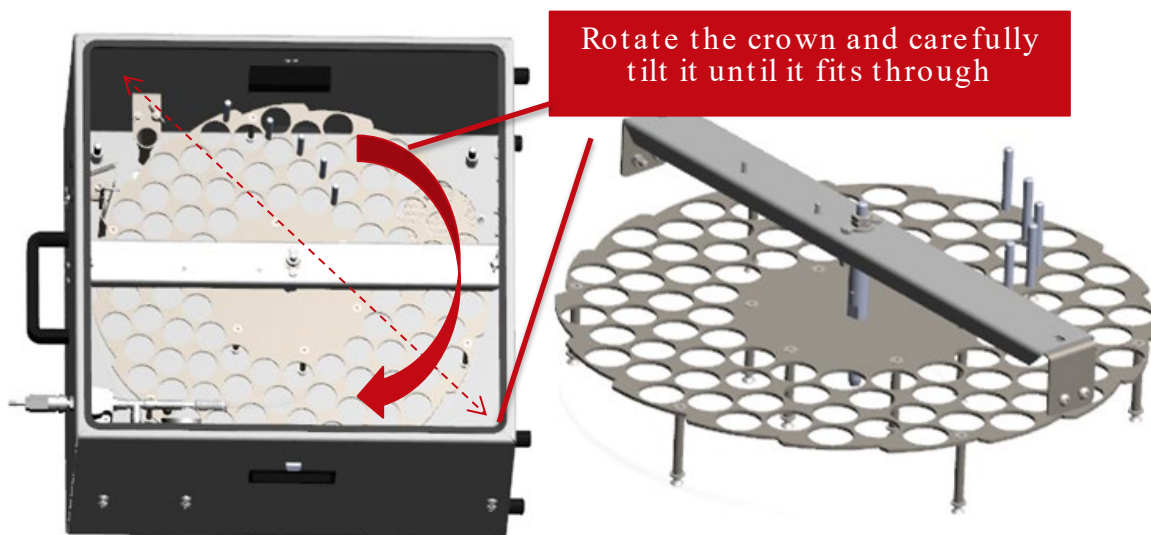

Figure 59. Disable the crown



The crown must be handled with care, as there is risk of injury or damage by impact.

7.2.4 Install the crown in the case.

The crown can now be mounted. Keep in mind to enable the drive system by removing the stainless steel chains, the spring and the antireverse system.

7.3 Scheduled maintenance

- The system should be checked every 6 months to ensure good performance.

Regular maintenance

Monthly : Check the silicone hose of the filling system and replace if necessary (it is recommended to change it every 2 months as a preventive measure and after using the device). See figure 53

Yearly : The following should be replaced:

- Recoil spring of the drive cylinder see figure 60
- Recoil spring of the Anti-reverse system. See figure 61

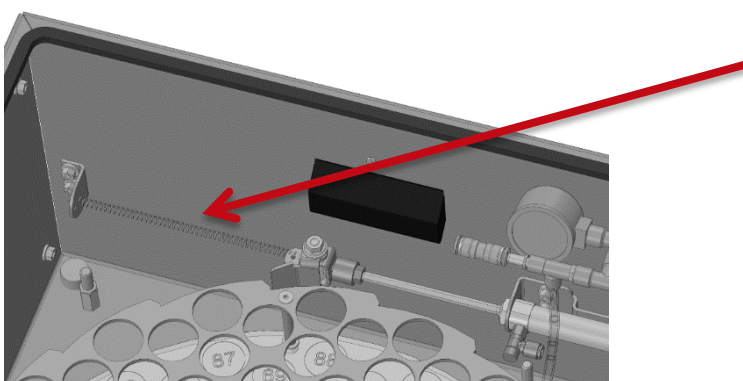

Figure 60. Change the spring of the drive cylinder

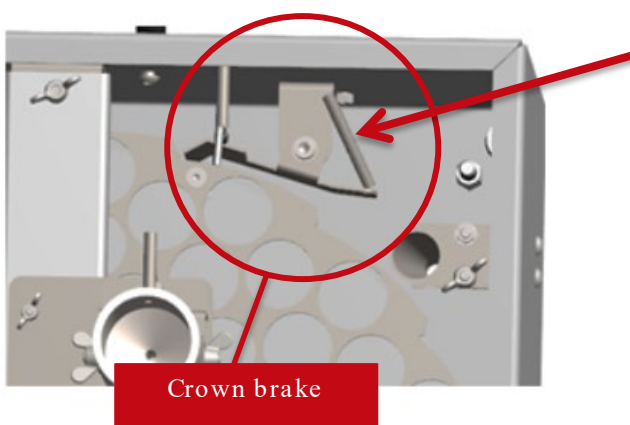

Figure 61. Spring of the crown brake



The system does not need any lubrication (it works on dry cylinders).



Inspect the cylinders, as they must be replaced if performing improperly.

8 Pneumatic circuit

8.1 Introduction

This chapter contains the information for air components parts, pneumatic circuit and test and adjustment procedures.

8.2 Air components parts

The sample works with the air pressure deliver by the Lely Astronaut, the robot controls the sampler for each operation. The maximum air pressure is 6 bar.

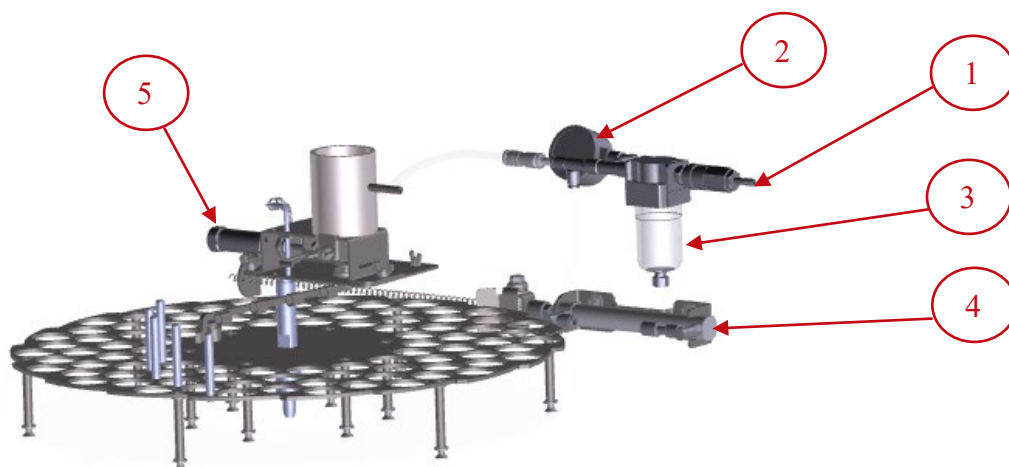

Figure 62. Overview of air components

KEY:

1. Air connection - 2. Manometer - 3. Purge for air inlet - 4. Cylinder to drive the crown - 5. Cylinder to fill the milk deposit

- Air connection: use the quick coupling supplied to connect to the robot.
- Purge for air inlet: this purge works automatically, the function is to protect the cylinder from any humidity, and extract the water.
- Cylinder 4 drives the crown and cylinder 5 allows the vial to be filled.
- The manometer notifies you when you have the right pressure from the robot.

8.3 Pneumatic circuit

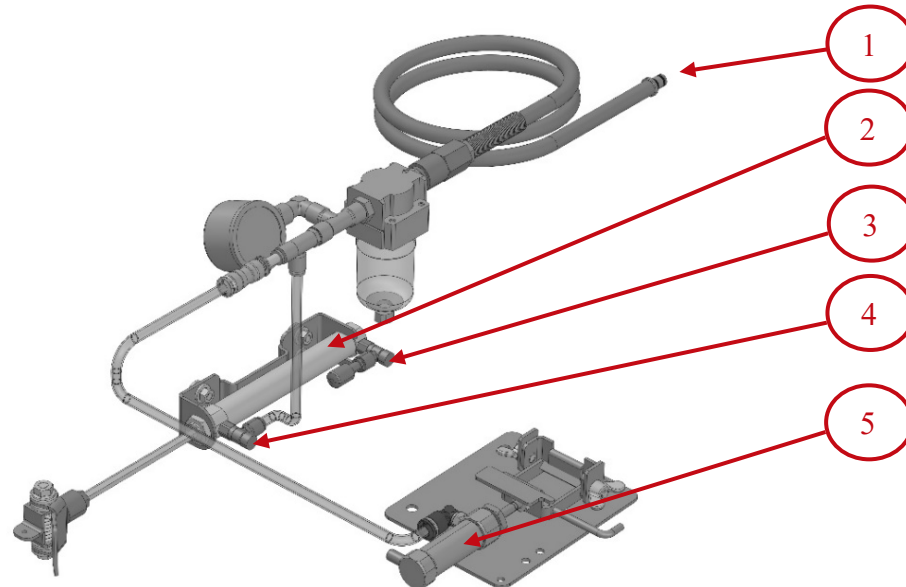

Figure 63. Overview of pneumatic circuit

KEY:

1. Air supply from the robot - 2. Cylinder to drive the crown - 3. Air regulator to adjust the speed of exit for cylinder rod - 4. Air regulator to adjust the speed of entry for cylinder rod - 5. Cylinder to fill the vial

The cylinder (2) is used to drive the crown which uses an external spring to exit the rod from the cylinder (standby position), the air regulator (3) adjusts the speed for the output of the cylinder, to retract the cylinder rod (2), the air regulator (4) adjusts the input speed, this cylinder is double acting. To adjust the air regulator, turn the wheel and lock the screw.

The cylinder (5) allows the bottle to be filled, the spring is inside the cylinder, the cylinder rod is always extended (standby position), when it is activated, the bottle fills, this cylinder is single -acting.

All cylinders are connected to the same compressed air line.

8.4 How the system works.

The system operates in 3 stages:

- 1 Standby position
- 2 Air pressure from the robot
- 3 No air pressure

8.4.1 Initial state

In the standby position, without air pressure, the cylinder (1) which drives the crown pushes the rod out, the cylinder (2) to fill the bottle with the rod out and presses the silicone tube, the dispenser changer tube is in position 1. (See figure 64)

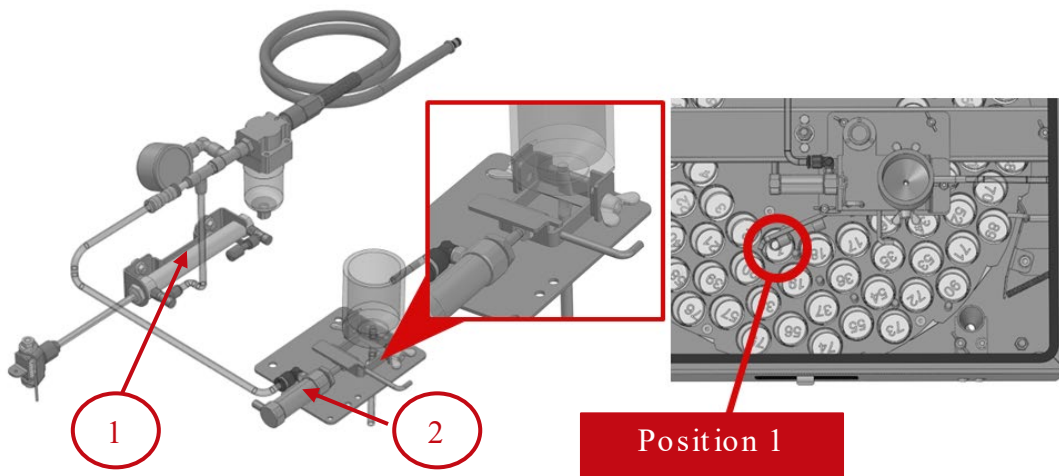

Figure 64. Standby position

8.4.2 Air pressure activated

With activated air pressure from the robot, the cylinder (1) retracts the rod, the cylinder (2) retracts the rod and fills the bottle. The dispenser changer tube is still in position 1. (See Figure 65)

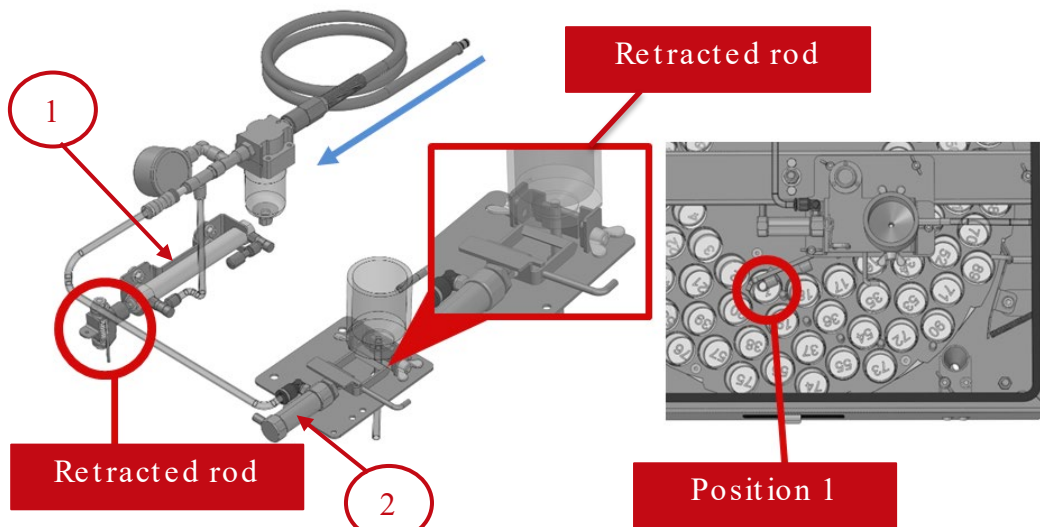

Figure 65. Air pressure on

8.4.3 Next position

Without air pressure activated by the robot, the cylinder (1) is released by the external spring, the crown rotates, and the dispenser changer tube is positioned in position 2. The cylinder (2) takes out the rod and presses the silicone tube, filling is finished (see Figure 66).

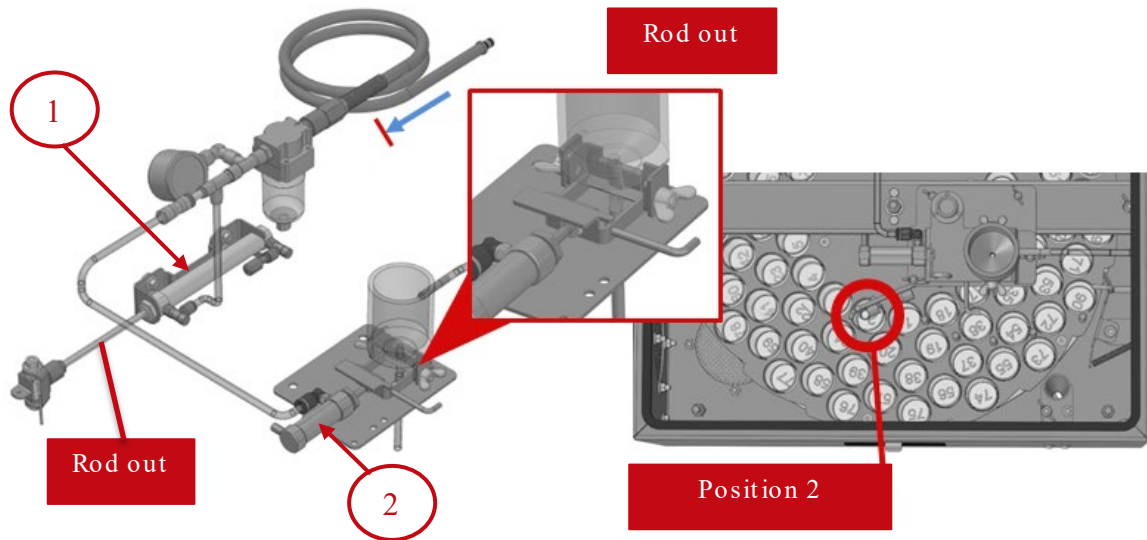

Figure 66. Next position

8.5 Test and adjustment

Description	Action
The crown moves very quickly	Check if the pressure is above 6 bar (1)
	Check if the air regulator is too open on the cylinder (3)
	Check if the spring is correctly installed
The crown does not move	Check if the pressure is at least 6 bar (1)
	Check if the air connection is correctly installed
	Check if there are no leaks in the circuit
The cylinder for the crown moves very quickly	Check if the air regulator is open on the cylinder (4 and 3)
The crown turns without stopping	Check if the plate brake is activated

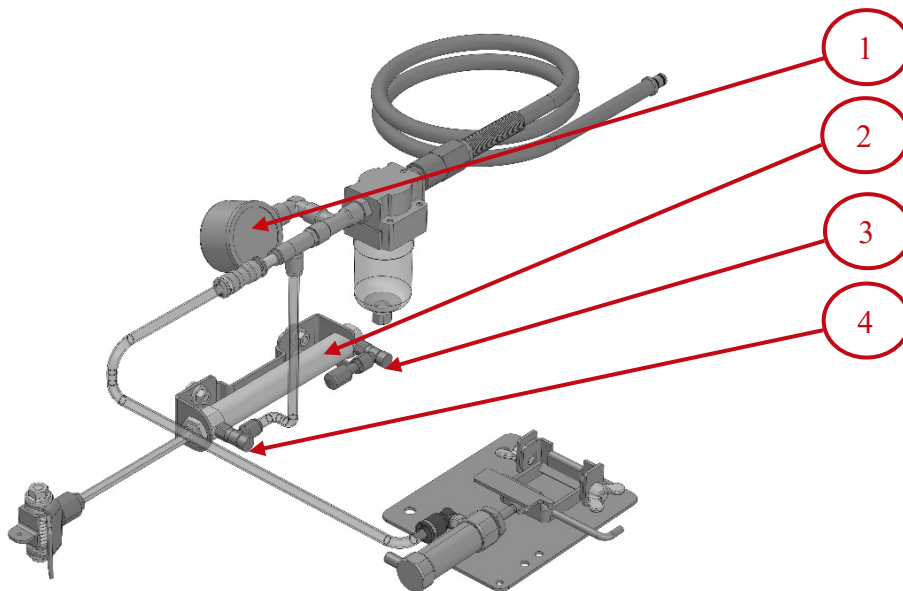

Figure 67. Test the crown

9 Troubleshooting

When operating the sampler, the following situations may occur:

Description	Action
The system does not sample cows	Check if the sampling sequence has been activated on the robot
	Check the compressed air connection
	Check the milking hose on the side of the robot
The system does work, but the bottle is overfilled	Check the release system of the filling cylinder
	Check the anti-reverse release system
	Check the drive cylinder
	Check the pressure in the manometer
The system moves 2 notches	Check the robot settings (Rotary sampler)
The bottles are not filled enough	Check the filling times on the robot E link

10 Disposal

Disposing this product correctly will help save valuable resources and prevent any potential negative effects on human health and the environment, which could otherwise arise from inappropriate waste handling.

Decommissioning and disassembly of the product can be dangerous and must be done only by qualified recycling organisations. All components must be disposed in compliance with local rules and regulations. Lubricants and fluids must be disposed correctly to prevent pollution of the environment. Read the safety data sheets of the used lubricants and fluids for correct disposal. All lubricants and fluids must be disposed in compliance with local rules and regulations.

Contact your local authority or local Lely service provider for further details.

11 Main spare parts

You can find here the spare parts numbers for the sampler. If you need more spare parts, please contact your nearest Lely Center

	Reference	Component
1	5.1504.1089.0	Drive Cylinder
2	5.1504.1092.0	Spring for Sampler type 60
	5.1504.1185.0	Spring for Sampler type 54,72,80, 90, 110 and 132
3	5.1504.1089.0	Cylinder for deposit
4	5.1504.1091.0	Spring brake
5	9.1065.0074.2	Silicone tube

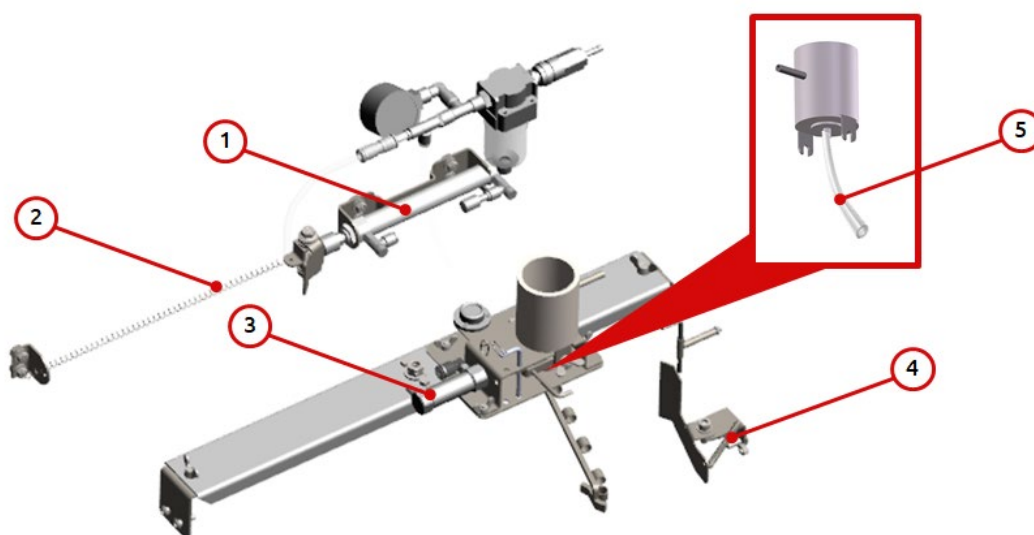

Figure 68. Overview of spare parts

12 Index

C	
caution	2-1
D	
danger	2-1
N	
note	2-1
S	
safety	2-3
maintenance safety	2-3-4
operating safety	2-3-2
safety decals	2-4
Specifications	3
W	
warning	2-1





Lely Industries N.V.
Cornelis van der Lelylaan 1
3147 PB Maassluis
The Netherlands
Phone: +31 (0)88 122 82 21
Fax: +31 (0)88 122 82 22

