

“Silent Herdsman^R”: A Scalable Approach to Heat Detection

Michael Gilroy¹, Craig Michie¹, Malachy Devlin¹, Annette MacDougall¹, Ivan Andonovic¹, Andy Warne², Jonathan Davies²

¹ETS Ltd, Ladywell Business Centre, 94 Duke Street, Glasgow, G4 0UM

²NMR plc, Fox Talbot House, Bellinger Close, Chippenham, SN15 1N, UK

Abstract

This paper reports on the deployment options of the “Silent Herdsman^R” a scalable heat detection platform representing a new generation of decision support systems that promote the principles of Precision Livestock Farming. The collar tag solution is flexible in terms of the number of cattle it can manage, the geographical coverage as well as providing information on individual animals in addition to heat events.

Keywords: heat detection, collar tags, decision support platform.

Introduction

Precision Livestock Farming (PLF) is core to satisfying the increasing world-wide demand for animal products of good quality and the increasing societal concerns over animal welfare and health, whilst heavily reducing environmental load and resource use. Animal husbandry involves monitoring animal health, wellbeing and productivity and then responding in an appropriate way when problems arise. This management is still largely executed by humans using skills that have not changed significantly in many years, but this approach is increasingly difficult to sustain. In many parts of the world, farming concerns are becoming larger to remain profitable and/or the cost of skilled labour is increasing; both of these factors reduce the opportunity for husbandry staff to monitor animals effectively. This paper details the development of a decision support platform embodied in the form of a smart collar – the Silent Herdsman^R - that promotes the implementation of precision farm management.

Technology is used in many different ways for monitoring in a range of industries and the collar based platform provides solutions within animal production to improve animal health by focusing the valuable time of animal husbandry staff onto those animals that most require attention. Animal wellbeing is at the start of a chain that links to farmer profitability, product quality, consumer satisfaction and environmental sustainability. The rationale is that if the needs of animals at the individual level are properly defined and met, then the needs of farmers and downstream stakeholders including consumers follow as a consequence. The more precisely that needs are met, the less waste there is in the system, resulting in greater environmental benefit. The collar is the basis for a highly scalable and highly functional decision support platform that assists in securing a sustainable food supply internationally.

Smart Collar Platform

The platform consists of an electronic box harnessed to a collar around the neck of a cow [1, 2, 3, 4, 5]. The solution records individual neck movements continuously using a 3-axis accelerometer similar to the Nintendo Wii console. The measured activity data is processed on-collar using artificial intelligence software able to identify changes from normal activity behaviour in the cow, e.g. the onset of heat. This heat event is downloaded to a PC wirelessly whenever a cow enters the receiving area of a base station, located either within the field, or within the milking parlour. Alerts indicating that a particular cow is entering heat are displayed on a local PC enabling the farmer to schedule insemination more efficiently. Accurate heat detection increases significantly the likelihood of pregnancy, which in turn leads to increased milk yields and increased profits to the farmer. The Silent Herdsman^R core platform is a solution that:

- maximises fertility
- maximises profitability
- reduces operational costs
- minimises insemination costs
- maximises operational efficiency through bringing automation to farm practices.

Each collar ‘learns’ normal behaviour patterns and alerts the farmer of cow conditions only when there is an indication of a high degree of confidence that intervention is required. Rigorous validation indicates that the signature algorithm predicts with an accuracy of 95% of all oestrus events, including some that on visual inspection, are not demonstrably displayed by the cow. The basic standalone platform comprises collars plus a base station and industrial PC. Additional elements can allow the farmer or service provider to access the data remotely e.g. service hub or PDA. A further, distinct differentiator, concerns the implementation of the model software directly on the collar, which results in a profound reduction of the volume of data required to be downloaded to the application; the solution only generates alerts, which are transmitted at critical periods. The net gain with such an approach is;

- scalability (can manage >1000 herd sizes)
- deployment adaptability to service various farm environments
- operating lifetime is in excess of 3 years without the need for battery change
- can be reprogrammed over-the-air.

Scalable Remote Access

Data is downloaded to a PC wirelessly (Figure 1) whenever a cow enters the receiving area of a base station, located either within the field, or within the milking parlour. A router within a control box enables additional base stations to be added to the network to increase coverage.

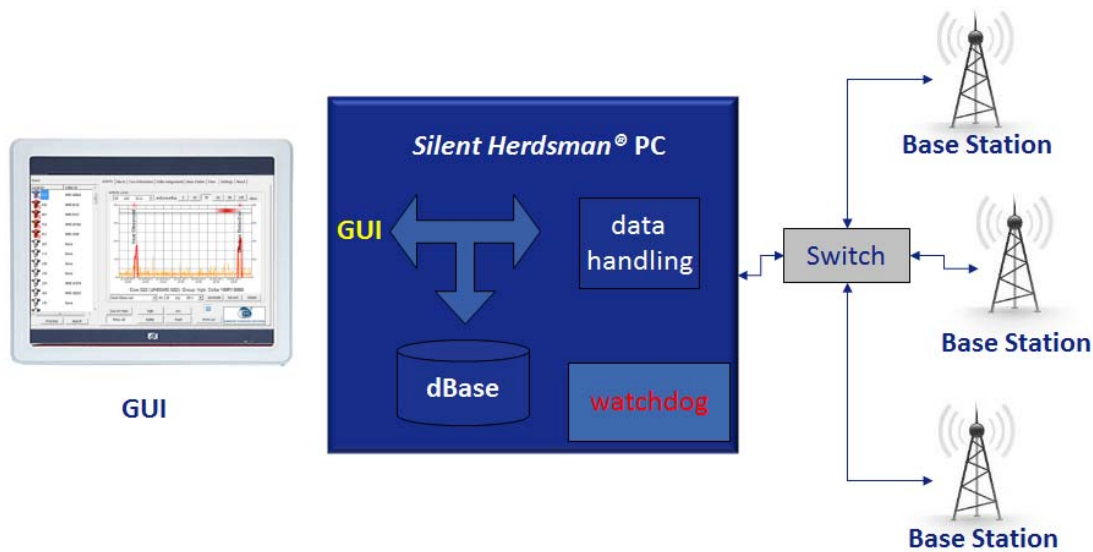

Figure 1: Silent Herdsman^R wireless downloads.

The PC displays the activity behaviour and patterns indicative of meaningful events (Figure 2).



Figure 2: PC display.

The router also allows increased scalability in terms of coverage (Figure 2), allowing the Silent Herdsman^R to connect to existing farm wireless/wireline infrastructure which in turn provides access to the Internet via an existing ADSL or an in-built 3G modem connection. In addition, this solution connects to any existing or deployed WiFi network enabling a number of further extensions to the platform;

- a wireless relay that connects a remote area with cattle e.g. heifers, located up to 2 km-3km from the central shed containing the farm PC

- a wireless bridge that connects the farm PC to a home PC which in turn becomes the gateway to the Internet. Alternatively, this could be used to remove the need for a touch screen PC and enable a lower cost PC unit to be utilised within the customer premises.

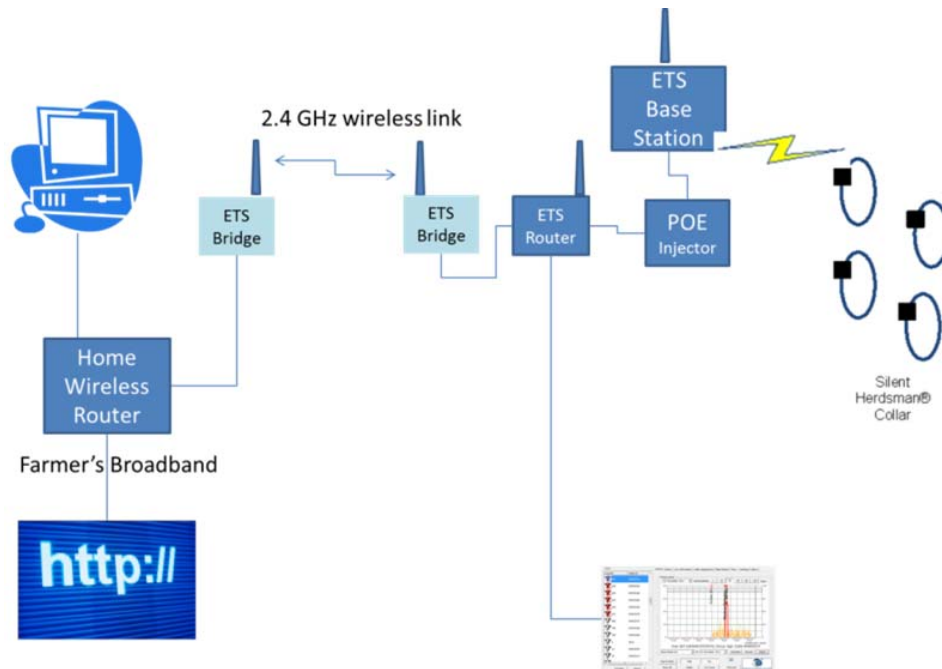

Figure 3: Silent Herdsman^R platform enhanced coverage.

Conclusions

The dairy market is focused on maximizing milk yields and leveraging the total revenue per cow, paramount to the business management processes within dairy farming. Highly scalable and highly functional technologies that assist in the evolution of precision livestock farming are fast becoming critical to the health of the industry. Farmers balance between sustainability and the need to invest in innovative technologies to maximize returns on farm. Silent Herdsman^R provides a catalyst to facilitating the dairy industries growing demand for milk by boosting on-farm herd performance.

References

1. K Sasloglou, I. A. Glover, H. G. Goh, K. H. Kwong, M. P. Gilroy, C. Tachtatzis, C. Michie, I. Andonovic, 'Antenna and Base-Station Diversity for WSN Livestock Monitoring' Wireless Sensor Network, vol.1, no.5 pp383-396, Dec 2009
2. B. Stephen, C. Dwyer, J. Hyslop, M. Bell, D. Ross, K. H. Kwong, C. Michie, I. Andonovic, 'Statistical Interaction Modelling of Bovine Herd Behaviours', IEEE Transactions on Systems, Man, and Cybernetics, Part C: Applications and Reviews, Issue 99, pp1-10, October 2010

3. Kae Hsiang Kwong, Tsung Ta Wu, Hock Guan Goh, Konstantinos Sasloglou, B. Stephen, I. Glover, Chong Shen, Wencai Du, C. Michie, I. Andonovic, "Implementation of Herd Management Systems with Wireless Sensor Networks", IET Wireless Sensor Systems, Vol. 1, Iss. 2, pp55-65, March 2011
4. I. Andonovic, C. Michie, M. Gilroy, Hock Guan Goh, Kae Hsiang Kwong, K. Sasloglou, Tsung-Ta Wu, "Wireless Sensor Networks for Cattle Health Monitoring", ICT Innovations, pp.21-31, (Editor: D. Davcev and J. M. Gomez)", Springer-Verlag, Berlin Heidelberg
5. K.H. Kwong, Tsung-Ta Wu, Hock Guan Goh, Konstantinos Sasloglou, Bruce Stephen, Ian Glover, Chong Shen, Wencai Du, Craig Michie, Ivan Andonovic, "Practical Considerations for Wireless Sensor Networks in Cattle Monitoring Applications", Computers and Electronics in Agriculture, 2011