

The system for highest reliability

# QUADTRAC®.....UNIFLO

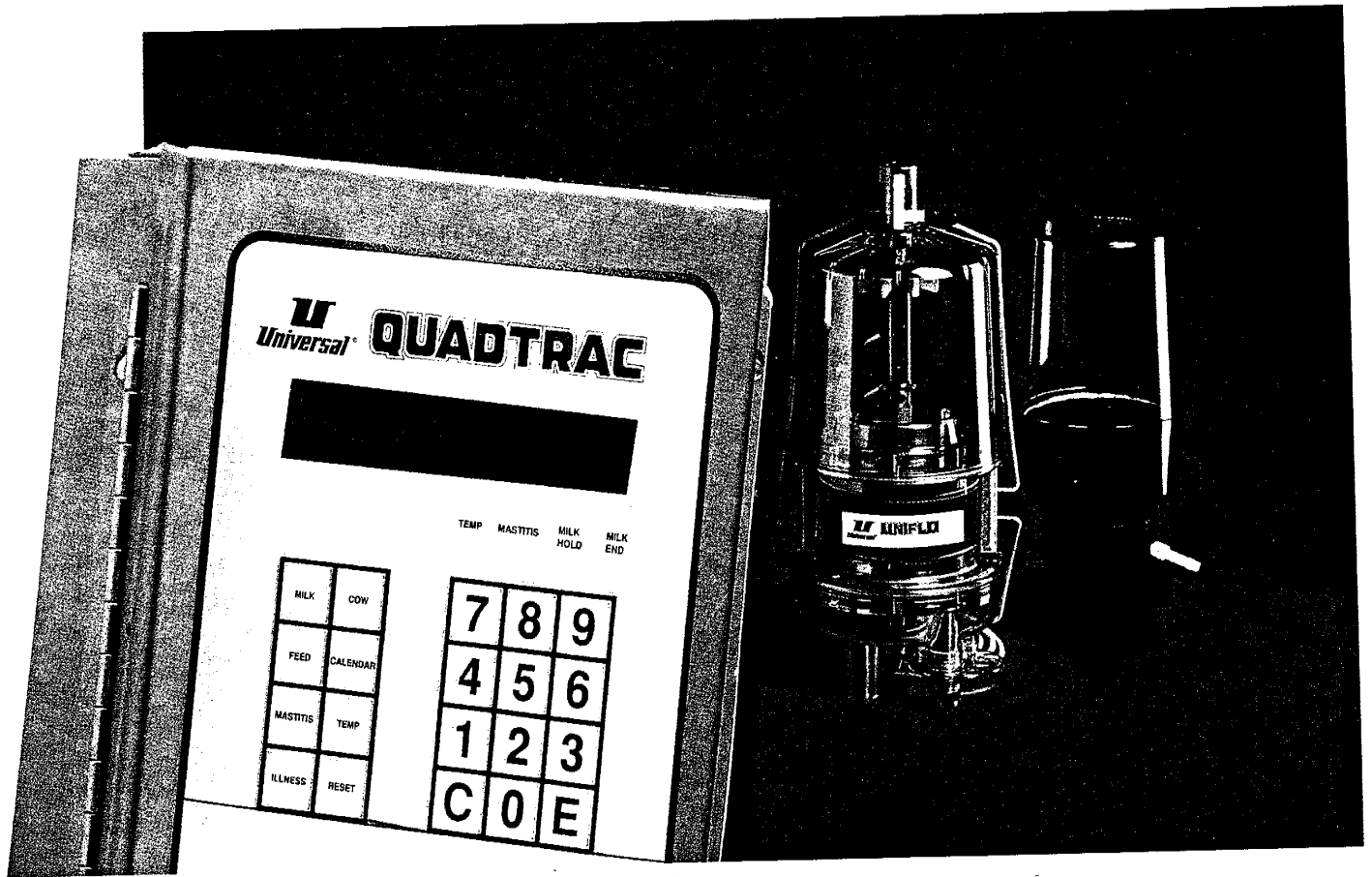

## ACCURACY

UNIFLO is a highly efficient milk meter designed to meet the highest demands on quality and durability. The meter has been designed in conjunction with today's high capacity milking units and is ICAR approved, meeting the most stringent regulation for accuracy in the world.

## HIGH CAPACITY

Thanks to the carefully optimized volume of the meter as well as to its wide inlet and outlet, it has a high milk flow

capacity at stable vacuum levels. It will cope with today's highest yielding cows, and yet still is compact and easy to install.

## FLEXIBILITY

The QUADTRAC gives an instant display of all key information as well as flashing alarm lights for warning of important attentions during milking. The Quadtrac has complete programmable take off functions.

  
TM  
**Universal**®

# The UNIFLO Meter is a link in the complete milk production system *from* Universal

The meter can be installed in all types of parlors as well as on stanchion or flat barn arrangements.

The UNIFLO system communicates automatically between the LYNX processing computer and the QuadTrac. When set to stand-alone version, the QuadTrac gives only milk yield but includes all the very advanced take off functions.

**The QuadTrac gives the milker the key information during milking.**

Warnings are shown with separate indication lamps. These warnings flash as soon as the cows are identified in the parlor.

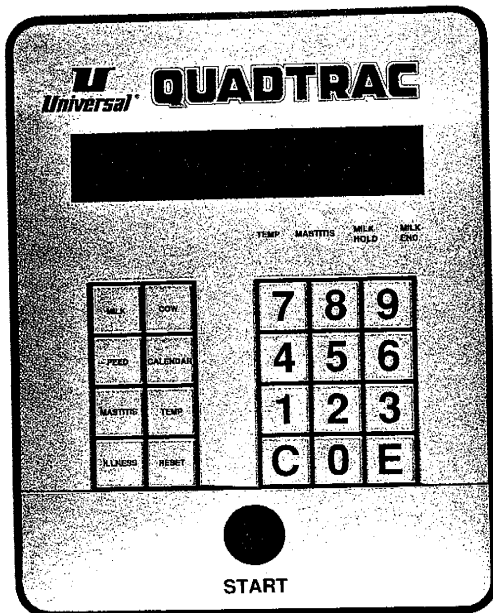
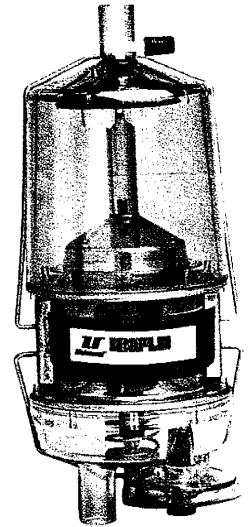

- Early kickoff
- Milk separation
- High milk yield
- Low milk yield
- Cow with colostrum
- High temperature
- Conductivity by quarter
- In heat
- Dry off
- Pregnant check
- Insemination



**U**<sup>TM</sup>  
**Universal**

Universal Dairy Equipment, Inc.  
11100 North Congress Avenue  
Kansas City, MO 64153-1222  
(816) 891-2430  
U428

# UniFlow/QuadTrac System

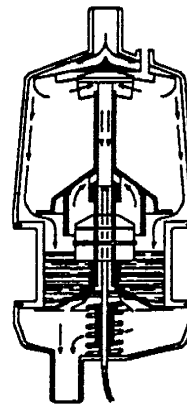
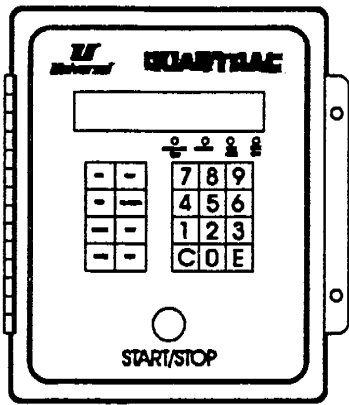

## User

- I. . . . . Introduction
  - A. . . . . Function/Overview
  - B. . . . . External Overview Of Quadtrac
  - C. . . . . Keys and their functions
  - D. . . . . Attention Lamp Overview
- II. . . . . Pre-Start Up Settings
- III. . . . . Operation
- IV. . . . . Cleaning Program

## Service and Installation

- I. . . . . Installation
  - A. . . . . Milk Meter
  - B. . . . . QuadTrac Control
  - C. . . . . Vacuum Take Off Cylinders
  - D. . . . . Wiring
- II. . . . . Programming
- III. . . . . Start Up
- IV. . . . . Customizing
- V. . . . . Calibration
- VI. . . . . Service
- VII. . . . . Trouble Shooting

## I. Introduction/Overview

### A. Functional Description of UniFlow.

The milkmeter is a volumetric measuring system, consisting of an inlet chamber (1) with milk inlet, a measuring chamber (2) and an outlet chamber (3) with the outlet for the milk weighed.

An inlet valve (4) and an outlet valve (5), together with a pipe (6), a swelling bellows (7), a spring (8) and a solenoid valve bring about an upper and lower closing motion.

The atmospheric air entering through the milking unit is used to weigh the milk. The milkmeter has such a construction that the milk and the air mixed together are separated in the inlet chamber. The milk and the air enter the measuring chamber separately and are mixed together in the outlet chamber.

The upper figure, shows the meter during the measuring stage. The outlet valve (5) is closed; the inlet valve (4) is open. The milk enters and flows directly to the measuring chamber (2), while the air goes to the outlet chamber through the pipe (6).

The milk is collected in the measuring chamber (2) and a contact (9) comes into action by means of a float (10) which moves as the level of milk rises. An electronic unit connected to this, registers the amount of milk and drives a solenoid valve. The swelling bellows drives the movement of the valves (lower figure) and the inlet valve (4) closes while the outlet valve (5) opens.

The milk inflow is collected in the pre-chamber (1) and the amount measured flows from the measuring chamber (2) to the outlet chamber (3). During this process, the air is detoured to the measuring chamber (2) through the pipe (6). Once the measuring chamber (2) is emptied, the meter repositioned for measuring.

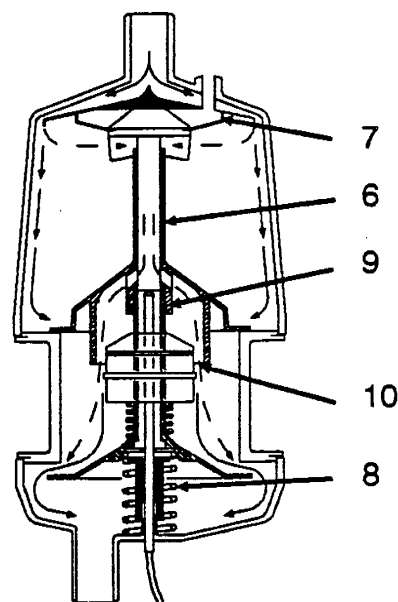
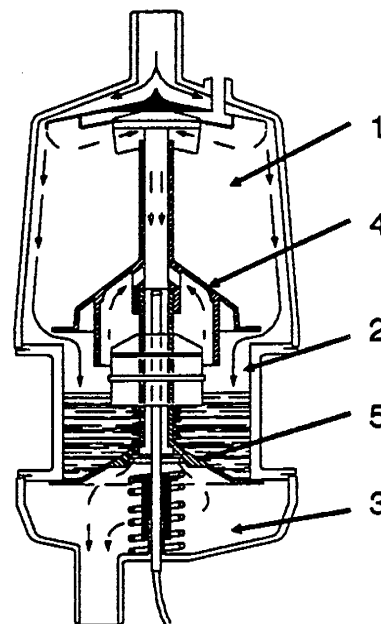
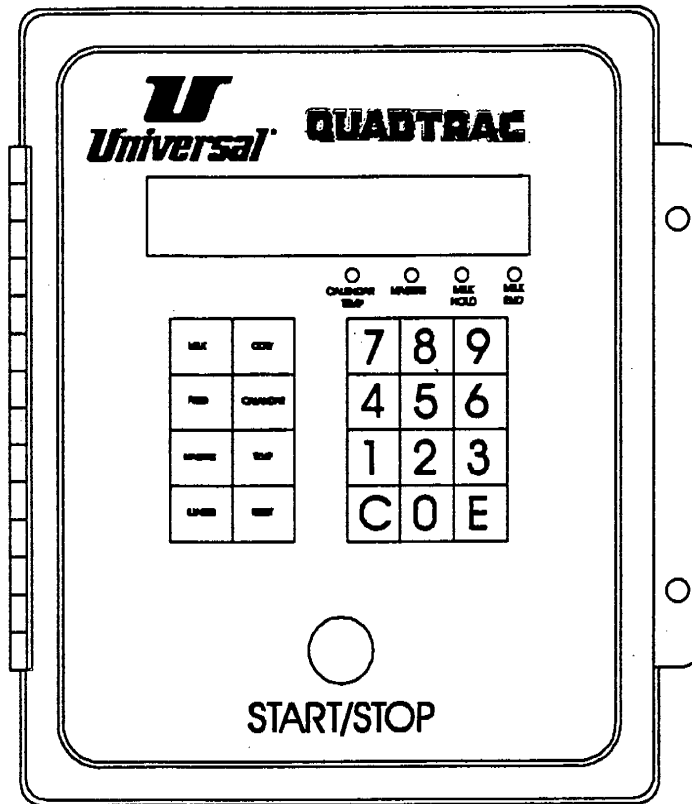

Figure 1

**B. External Overview of Quad Trac**



**Figure 2**

<b>Overview of display keys</b>	
C	Change, clear button
E	Store key, to confirm changed data
0	Numerical key, decimal point and "No"-function
1	Numerical key and "Yes" - function
2-9	Numerical keys
MILK	Milk data
COW	Cow data
FEED	Feed data
CALENDAR	Cow calendar data
MASTITIS	Conductivity data
TEMP	Temperature data
ILLNESS	Illness codes
RESET	Reset button. Also start and stop button
START/STOP	The start and stop button.

## C. Keys And Their Functions

The Keys are divided into two sets. The right hand set of 12 keys are used for programming and operation. The left hand set of 8 keys are function keys which can be used to retrieve value on cows currently in the milking stall.

### 1. Programming/Operation Keys

#### C-key

The C-key (Change, Clear) key can be used to open a field for changing the data. Pressing the C-key, the display starts flashing. During flashing, bars are placed on the display.

#### E-Key

The E-key will be used to store data after changes are made in a program.

#### Keys 0-9

The numerical keys are used to change the numerical value for different functions during programming, or to add numerical values to a cows record during the milking session. Note ! "0" can be decimal point or mean or "No" and "1" can mean "Yes".

#### Start Button

The "Start" button releases the milking unit, when pressed again it retracts the milking unit. For override of milk separation and colostrum, the start has to be a combination of "Illness" and "Start" buttons.

## 2. Function Keys

During milking, when a cow is identified, a number of different areas of information about the cow, or the milking, can be showed on the display by using the function keys. The text below describes how to handle the function keys and what kind of information can be displayed. In this manual an "I" after the displayed text means that the data can be changed manually. An "O" means it is a computer calculated data which can only be viewed.

### NOTICE

*After pressing a key for information, the display goes back to default after 5 sec. or the timed programmed in function number six (6), screen.*

### Function Chart

Key	# of times Key Must be Pressed to Access Data	I - Data can be changed O - Computer calculated data only	Display		Information Available
			Program Code	Numeric Value	
Illness	1	I	C O D E 1	X X	Illness code 1, last 2 digits of illness code1 in process computer
	2	I	C O D E 2	X X	Illness code 2, last 2 digits of illness code2 in process computer
Mastitis	1	O	R F	X X X	Conductivity value Right Front quarter
	2	O	R R	X X X	Conductivity value Right Rear quarter
	3	O	L R	X X X	Conductivity value Left Rear quarter
	4	O	L F	X X X	Conductivity value Left Front quarter
	5	O	P R F	X X X	Conductivity value previous milk session RF quarter
	6	O	P R R	X X X	Conductivity value previous milk session RR quarter
	7	O	P L R	X X X	Conductivity value previous milk session LR quarter
	8	O	P L F	X X X	Conductivity value previous milk session LR quarter

## NOTICE

*The conductivity values which are displayed, are the average values, of individual quarter, which are measured during the milk session. When one of the above mentioned values flashes, when pressing the conductivity data key, the flashing value exceeds the signal threshold values, which are programmed in the computer.*

**Function Chart**

Key	# of times Key Must be Pressed to Access Data	I – Data can be changed O – Computer calculated data only	Display		Information Available
			Program Code	Numeric Value	
Feed-Key	1	I	F E E D M X X X		Total Feed2 when not feeding in the milk parlor, or the amount of programmed feed for the milk parlor per milk session by in parlor feeding. During milking, feed can be manually provided by entering an amount in this field. Maximum amount 29.9 kg.
	2	O	F E E D 1 X X X		Total day feed
	3	O	B A L 1 X X X		Cycle balance feed
	4	O	B A L 2 X X X		Cycle balance feed
	5	O	F D P E R X X		Current feed period



**Function Chart**

Key	# of times Key Must be Pressed to Access Data	I - Data can be changed O - Computer calculated data only	Display		Information Available
			Program Code	Numeric Value	
Milk-Key	1	I	M I L K	X X X	The actual registered milk yield or the manual entered milk yield
	2	O	M I L K T	X X X	This is the minimum milk weight expected from the cow at this milking. This is calculated based off of the 24 hour rolling average and the allowable deviation in percent. (Deviation is programmed in the main computer).
	3	I	S E P M L K	X X	Separate Milk, number of milkings, including the present milking, the milk of the cow should be separated.
	4	I	M L K S P	X X	The average measured milkspeed (kg. or lbs. /min.), the milk- speed is calculated as follows: (amount of milk/time between first pulse and retraction point of time)
	5	I	M A X S P	X X	The maximum measured milkspeed (kg. or lbs. /min.), this is the amount of one milk portion divided by the shortest time between two milk portions
	6	I	T I M E	X X	Total milk time (10th of minutes), time between first milk portion and retraction point of time
	7	I	C O L O S T	X	Colostrum milk Yes or No

**Function Chart**

Key	# of times Key Must be Pressed to Access Data	I – Data can be changed O – Computer calculated data only	Display		Information Available
			Program Code	Numeric Value	
Cow-Key	1	I	C O W	X X X X	Cow number
	2	I	A C T	X X X X	Activity deviation (%), display flashing in case of an activity attention
	3	I	R E S P	X X X X	Responder number
	4	O	G R O U P	X X	Present group number in process controller
	5	I	S E P C O W	X	Cow separation, entering a "1", a cow will be separated by a separation transmitter/receiver
Calendar-Key	1	O	L A C T	X X X	Number of days a cow is in lactation.
	2	I	H E A T Y	X X X	Cow in heat, farmer manually entered Yes in this milk session
		I	H E A T N		Cow not in heat, entering Y, the cowstatus will be changed to in heat and the current date will be fill in the field"heat" of the process controller
		I	H E A T ?		Heat attention, Process controller has calculated an in heat attention for this cow
	3	I	I N S E M	Y	Cow is inseminated, farmer manual entered Yes in this milk session
		I	I N S E M	N	No insemination attention, entering a "1" means, the current date will be fill in the field "heat" of the process controller and the field "Inseminate" will be Yes

**Function Chart**

Key	# of times Key Must be Pressed to Access Data	I - Data can be changed O - Computer calculated data only	Display		Information Available
			Program Code	Numeric Value	
Calendar-Key	3	I	I N S E M	?	Insemination attention, process controller has calculated an insemination attention for this cow.
	4	I	I N C A L F	Y	Cow is in-calf
		I	I N C A L F	N	Cow is not in-calf, entering Y, the cowstatus will change to in-calf, the field "incalf" in the process controller will be set to Yes
		I	I C A L F	?	Attention in-calf control, process controller calculated this attention. Entering Y, the cowstatus will change into in-calf
	5	I	D R Y	Y	Cow status is dry
		I	D R Y	N	Cow is not dry. Entering Y, the cowstatus will change into dry and the field "Dry Off" in the process controller will be filled in with the current date.
		I	D R Y	?	Attention dry off cow. Entering Y, the cow status will change into dry

**Function Chart**

Key	# of times Key Must be Pressed to Access Data	I – Data can be changed O – Computer calculated data only	Display		Information Available
			Program Code	Numeric Value	
Temp -Key	1	I	T E M P X X X		Actual highest measured temperature in degrees
	2	O	T E M P T X X X		Temperature test value, maximum temperature before the QuadTrac generates an attention. The test value will be calculated by the process controller. The temperature test is equal to the average temperature of previous day or evening milk added by the standard deviation multiplied by a factor. The factor is factor 1 in normal situation and factor 3 when a cow is in heat.

## D. Attention Lamp Overview

On the front panel of the QuadTrac there are four different colored lamps. The function of these lamps are to give the farmer attentions. The meaning of these attention lamps are mentioned below.

Attention Lamp Chart			
Alarm Light	Color	Display	Attention or Warning Information
Calendar/Temperature	Orange	Flashing	In Heat Attention insemination Attention in Calf Attention dry Off Attention
		On Continuously	Milk temperature is elevated above normal.
Mastitis	Red	On Continuously	This lamp is switched on when the conductivity of one or more quarters exceeds the signal thresholds.
Milk Hold	Yellow	On Continuously	When the milk of the cow should be separated, the lamp is continuously on.
		Flashing	In case of colostrum milk the lamp blinks during milking.
Milk End	Green	On Continuously	The green lamp is switched on when the milk flow gets below the minimum threshold flow level (default 0.3 kg./min. or .61 lbs/min) during a programmed time (stripping time).
		Flashing	The lamp blinks when the registered milk yield is less than the minimum expected milk yield, calculated by the computer.

## NOTICE

*The display will show the cow calendar attention until the first milk dump is registered. Check the attention by pressing the cow calendar key until you see the attention with a question mark after. The lamp goes off when one of these attentions, with exception of the dry-off attention, is reset.*

## II. Pre-Start up Settings

The system can be customized in various ways. The service technician should go through all the options and change them to fit Your needs.

QuadTrac Operation Functions & Primiters			
Function/Display	Recommended Setting	Description	Default
Language (L A N G)	As Required	Terminal Which Language will be displayed 0=English, kg 1=Dutch 2=French 3=German 4=English, pounds	0
Display Time (S C R E E N)	5 - 10	You can change the time information is shown on the display when a function button is pushed between.	5 Sec
Time Till Clean Mode (C L T I M E)	10	Time between opening of the exit gate and changing the state of the QuadTrac to cleaning mode.	10 Min
Let Down Delay (N E U T)	60-90	To prevent any take off during the first period of the milking session. During this time no take off is possible. This is due to cows with difficulties in the milk let down in the beginning of the milking. To change this presetting, please contact your service man. If, during this time, the milk flow rate is never reached the pre-set "threshold value", the unit will be removed and the display will flash quickly.	120 Sec
Milk Flow Rate Setting (F L V L)	.5 to .7 Lbs/Min 250 to 350 G/Min	Level of milk flow required to keep unit on cow. Milk flow rates below this threshold level will start the take off process	.61 Lbs/Min or 300 G/Min
Take Off Delay (D L Y)	1500 - 2500 Ms	To avoid pulling the unit off the udder of the cow, there is a time delay between the vacuum shut off and the take off signal. This means that the vacuum is neutralized in the claw before the take off cylinder retracts the unit.	2000 Ms
Milk Time (S T R P)	10 - 20 Sec.	Time delay for vacuum "shut off" and "take off" of unit, after milk flow rate is beneath the threshold value.	15 Sec.

**QuadTrac Operation Functions & Primiters**

<b>Function/Display</b>	<b>Recommended Setting</b>	<b>Description</b>	<b>Default</b>
Clean Time (S T D B Y)	60 – 90 Min.	Time the meters will be in cleaning mode.	60 Min.
Kick Off Factor (K F A C)	4 Times	This factor controls what the QuadTrac identifies as a kicked off claw or as a normally ended milk session. If the milk flow suddenly stops it could either be because the cow is finished or the unit is kicked off. Ex The factor is 4. Now if the milk flow suddenly is 4 times slower the QuadTrac will think there has been a kick off.	4 Times
Lowest Kick Off Level (K L V L)	800 – 1200 Grams	Under this flow level the kick off detection is deactivated.	1000 Grams

### III. Operation

Depending on what kind of equipment is installed the QuadTracs will show different kind of attentions. The text that describes functions that requires a computer is marked with a (c).

#### A. Starting the milking.

- Close the exit gate and open the entry gate.
- The display should show "C O W".
- Load the cows into the milking parlor.
- Close the entry gate

#### B. With automatic cow identification (c)

The QuadTrac will automatically display the cow number of the identified cow when the cow passes the I.D. antena.

If a cow is not identified the display will continue to flash cow? Identify the cow and enter her number manually into the QuadTrac.

Press "C" to clear display.

Press numerical keys to enter cow number (example 123).

Press "E" to enter value.

## NOTICE

*If some cows are incorrectly identified, change only the first faulty cow and the rest of the cows will automatically be changed and corrected.*

#### C. With manual cow identification (c)

- Identify the cow and enter value.

Press "C" to clear display.

Press numerical keys to enter cow number (example 123).

Press "E" to enter value.

## NOTICE

*If a cow is not identified, it is possible to show the milk yield with the milk data button.*

#### D. With no cow identification.

There is no need to enter a cow number as the QuadTrac cannot process it.

When the cows are correctly identified and prepared, you can start the milking and attach the unit.

#### E. For automatic take off

- Press the "Start" button just once.
- The unit is released and you can attach it.
- When the first milk is recorded through the milk meter the display changes from "C O W 1 2 3" to "M I L K \_ \_ \_ \_" At the end of the milking when the cow is done, the unit will be automatically removed after the preset threshold value and stripping time requirements are met.



- If the cow doesn't reach the minimum flow level (programmed threshold value) within the programmed Let Down time or if the claw is kicked off during milking it will be retracted and the display will flash quickly.
- In case of early take off or kick off: clean the claw, push the start button and continue milking.

The display indicates the right take off and milk yield according to expectation with a green lamp. (c)

When take off is correct but milk yield is less than expected, the green lamp is flashing. (c)

## NOTICE

*If the unit is kicked off during milking, please press the "Start" button and attach the unit again.*

- To change from Automatic to Manual take off and vice versa during the milking cycle. Press "0" and "start" button in sequence.
- The unit can be removed at any time during the milking session by pressing the "Start" button.

### F. For manual take off

- Press the "Start" button just once but for approx. 2 sec or Press "0" and "Start" button in sequence.
- The QuadTrac will verify the manual take off by flashing once with all the indicator lamps as well as dots between C. O. W. and M. I. L. K.
- The unit is released and you can attach it.

- In case a unit is kicked off a cow during a manual milking, the Start Button must be pushed to close the vacuum to the claw and retract the unit. Clean the unit and press the Start Button again to reattach the milking unit.
- In case of early take off or kick off: clean the claw, push the start button and continue milking.

- At the end of the milking, when the cow is finished, according to the preset threshold value and milk time, the display will flash slowly, but unit will not detach.

The display indicates the right take off and milk yield according to expectation with a green lamp (c).

When take off is correct but milk yield less than expected, the green lamp is flashing. (c)

- To change from Manual to Automatic take off and vice versa, press "0" and "Start" button in sequence.
- The unit can be removed at any time during the milking session by pressing the "Start" button again.

### Separation of milk (c)

When the cow is treated with antibiotics, is dry or due to colostrum milk, the milk is separated. The number of milkings the milk should be separated, is set in the computer or in the QuadTrac. Separation of milk is indicated by the yellow lamp and the unit cannot be released in the normal way.

- To release the unit with separation or colostrum attention:
- **Press "Illness" and the "Start" button in sequence.**  
The milking procedure can then either be set for Automatic or Manual.  
For Automatic take off, press:

**Press "Illness" button and then the "Start" button short**  
For Manual take off press:

**Press "Illness" button and then the "Start" button for 2 sec.**  
Parameter

#### Activity Attention (c)

In case of "Activity Attention", the display will show the cow number and the "Activity Deviation" percentage ("ACT xxx"). The display alternates the cow number and the activity until the first milk dump is registered. After the first milk dump is registered, only the milk yield will be displayed.

#### Cow calendar attention (c)

If a cow has a cow calendar attention, this will be displayed until the first milk dump is registered. The cow calendar attention is modified by using the particular function key.

#### G. Reset of QuadTrac

When the milking session is over the cows are let out. The QuadTracs are automatically reset by a reset switch (switches) and the milking parlor is ready for a new row of cows. All data from the QuadTrac's is automatically transferred to the computer.

#### H. End of the Milk Session

After the end of the milking session, the gate should remain open. After the "Cleaning time" (pre-set to 10 minutes) the QuadTracs goes automatically into cleaning position.

The QuadTrac cleaning program is activated and the cleaning can start. The outputs will be set for cleaning to protect the electrical valve(s).

## 1. Fat Sampling

- Before sampling
- Make sure the air inlets in the milk claw and milk meters are opened.
- Disinfect the sample equipment in a cleaning solution
- Remove the rubber plug from the sampler ring
- Attach the sampler to the meter.
- Connect vacuum supply to the sampler

Make sure that all equipment for sampling contains no water residues.

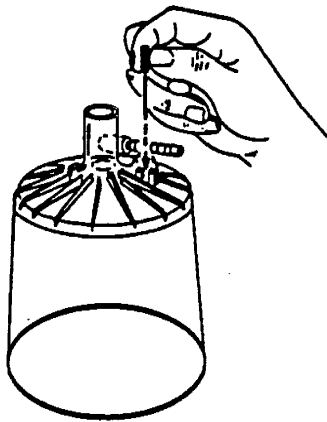

Figure 3

### Taking the Sample

- The display of the meter should always be at zero when the milking is started.
- After manual or auto take off, read the display and remove the sample bottle and replace it with a new one.
- Agitate the sample and pour it into the sample cup.
- Place the empty sample bottle upside down to drain off.

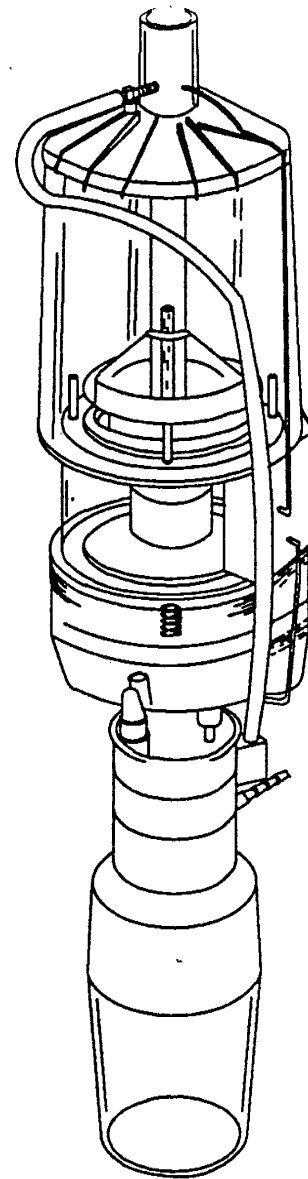

Figure 4

### After Sampling

- Remove the sampling equipment and disassemble the sampler adapter and clean all pieces carefully by hand in a cleaning- and disinfecting solution.
- Store the sampling equipment in a dry and dust free place.

## IV. UniFlow Cleaning Program

The QuadTracs goes into cleaning position after a pre-set time (default 10 min.). The gates must be open. At this <sup>Time</sup> moment the display shows "Clean". The individual QuadTracs start with a few seconds delay from each other. This time depends on the address of the QuadTrac. The time delay is equal to address x 5 sec.

### NOTICE

*The cleaning can also be started manually by pressing "Illness" button and Milk Data " in sequence when exit gate is open.*

After the time delay the QuadTrac starts the cleaning and the display shows the cleaning phases.

C L E A N 0

Close milk meter inlet valve

C L E A N 1

Fill inlet chamber with water

C L E A N 0

Open inlet valve

C L E A N 2

Valve kit working as during milking

C L E A N 0

Close outlet valve

C L E A N 3

Fill measuring chamber continuously

After the C L E A N 3 phase, the QuadTrac starts with C L E A N 0 again. When the "Stand by" time is over, the QuadTrac stops the cleaning program. The QuadTrac goes into a sleep mode and shows eight points on the displays. The cleaning program can be restarted by pressing "Illness" button provided that the QuadTrac is in the sleep mode. The duration of the cleaning phases and the "stand by" time is programmable in the service program (check with your service man for advice).

### Stand-by Time

When the cleaning session is over, the QuadTrac goes into "Stand by, or the sleep mode," after a pre-set time (default 60 min.). The QuadTrac and the valve outputs are deactivated for protection and safety.

# Service and installation

## I. Equipment Installation

### A. The Milk Meter

The meter can be installed and positioned in many different ways using the provided bracket.

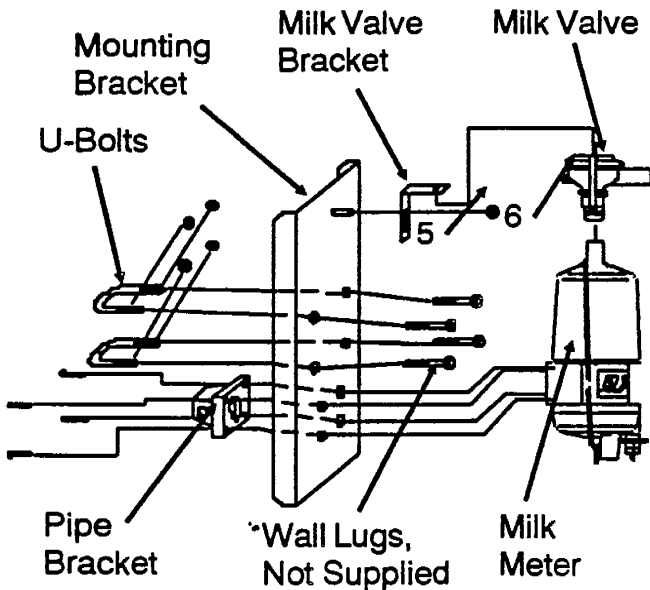

Figure 5

There are some basic rules to remember when you are mounting the meter.

- The meter must not be leaning more than +/- 5 degrees any direction.
- Use provided outlet hose (7/8" I.D.) to connect meter to the milk line.
- The outlet hose, must slope downwards a minimum of (15 deg.) to drain properly.

- Use the 100" bellow tube provided in package to connect the air valve to the bellow. This tube can be shortened but must not be extended.
- Make sure to leave enough room for the fat sampler under the meter if this is going to be used.
- Leave enough room underneath the curb and pipe line for the meter to be opened. Especially make sure the bottom chamber of the meter can be opened if service is needed.

Consider these rules and plan the meter mounting by them.

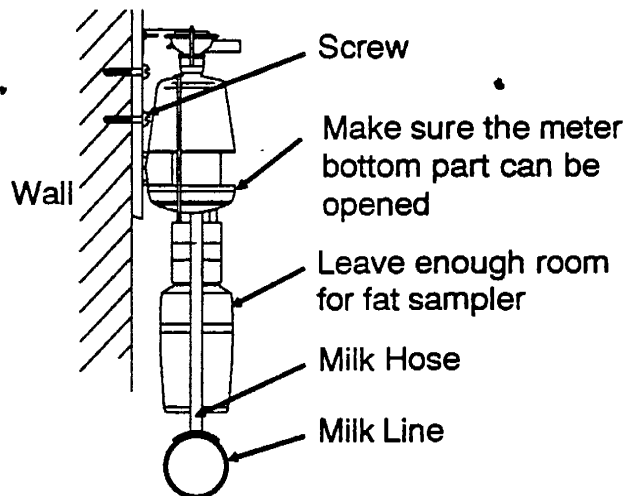
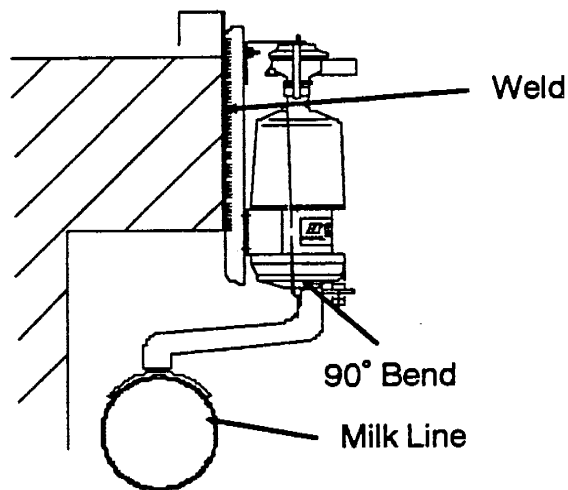

Figure 6

Following are some examples of meter mountings.



**Figure 7**

1. Welded directly to parlor curbing.

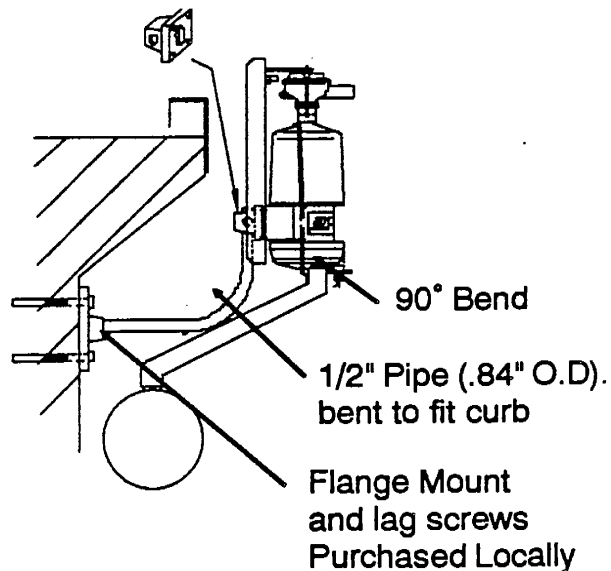

**Figure 8**

2. Mounted on 1/2" pipe using pipe bracket PN 670034.

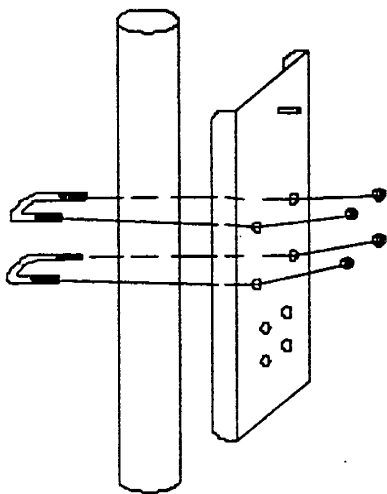

**Figure 9**

3. Mounted on a Vertical 1-1/4" pipe.

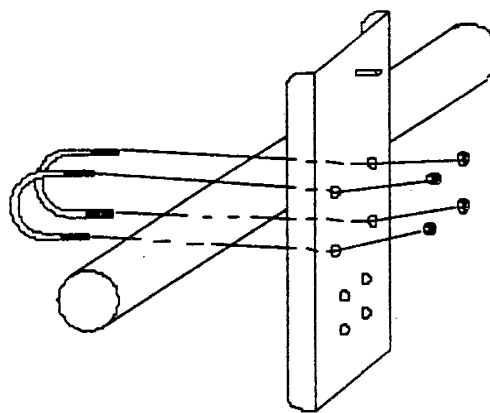

**Figure 10**

4. Mounted on a Horizontal 1-1/4" pipe.

Make sure the milk nose under the meter will reach the milk line when mounting on pipe.

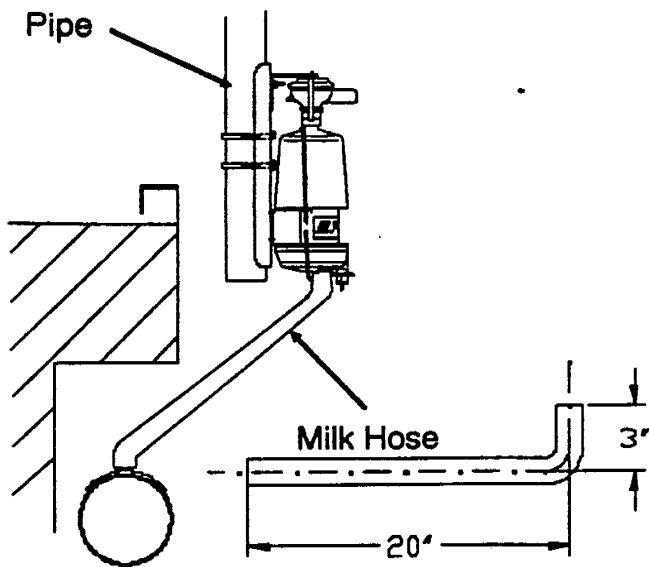

Figure 11

### The Bellow Valve

The bellow valve, should be installed on a minimum (2) inch or a (3) inch dia vacuum line as shown in Figure 12 with metal part up. It can sit either under the pit edge or above. Make sure the wire connector does not point up and the provided 3/16" I.D. hose reaches the meter top. This hose must not be longer than 100" but it can be shortened.

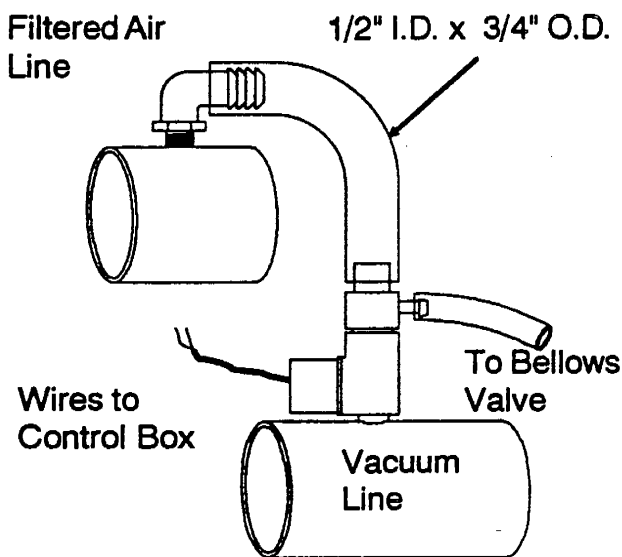

Figure 12

Install a free air line close to the valve and push a 1/2" I.D. hose on to the threaded valve top and connect this hose to the free air line with a 3/8" NPT x 1/2" Hose Barbed Elbow. The bellow valve will need 0.04-0.08 cfm of free air.

CAUTION

*For proper operation and servicibility, the bellow valve must be connected to a filtered air line. Failure to do so may cause promature failure and improper operation of the valve.*

### Dual Split Output Coil Valve

The Dual Coil assembly is an air valve which can operate either milk valves or vacuum operated take off cylinders from either a single or two separate QuadTrac Control Units.

The coils on this air valve can be identified from the pulsator coil by the three (3) following features.

- The Air ports on top of the coil are a large diameter.
- The Dual Output coil will be black in color, the pulsator coil will remain blue.
- The Dual Output coil will have two (2) terminal connections on the rear of the coil which the pulsator coil will not have.

#### a. Installation of Dual Air Valve Assembly

The Dual Split Air Valve can be mounted on a 2", 3" or 4" vacuum/pulsation line. Locate the valve as close as possible to the components to be operated. Using a Universal valve template (PN 313626) drill two 15/32" holes in the top of the vacuum/pulsation line.

Check to be sure the rubber seals are installed on the valve inlet tubes, and set valve on line with inlet tubes in the two 15/32" holes. Insert S.S. gear clamp through slots in the center of the lower base assembly and around the 3" line. Tighten clamp until unit sets firm on line and seals have made good contact with pipe, eliminating any vacuum leaks.

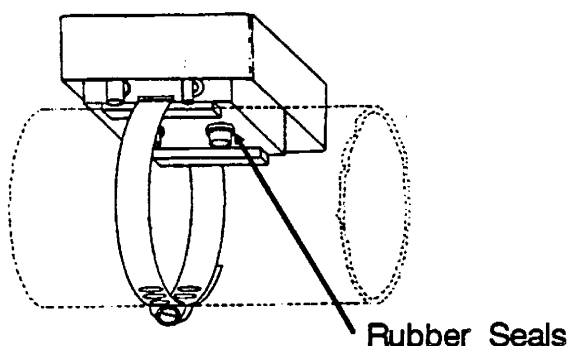

Figure 13

- For 2" or 3" vacuum lines use one seal per vacuum inlet tube.
- For 4" vacuum lines use two seals per vacuum inlet tube

A two conductor 18 gauge wire must be run from a pair of coil terminals in the dual split air valve to the QuadTrac Control box. Connect the air valve to the milk valve (s) with a 3/16" hose or to the take off cylinder (s) with 3/8" hose. Each valve can operate one take off cylinder and one milk valve, or two milk valves, or two take off cylinders.

The valve comes standard with two 3/8" elbows to connect a filtered air line to the cover. Since little air movement is required in this application a 1-1/2 inch PVC line is adequate. Be sure to run the line to a dry well ventilated area. A filter is required to keep large particles or rodents from entering the pipe. With the proper reduction a 313294 filter assembly can be used.

Screw one 1/4" NPT x 3/8" nose barb elbow into the 1/4" tapered hole on the pulsator cover. Install the large O-Ring on the pulsator cover and then place cover over the pulsator coils with the 3/8" elbow to the rear of the pulsator. Secure cover in place using a plastic acorn nut. Install the second 3/8" elbow in the filtered air line and connect to pulsator with 3/8" hose. (Hose is not included with the pulsator). (See Section P, page 36, 37 for further information on filtered air lines.)

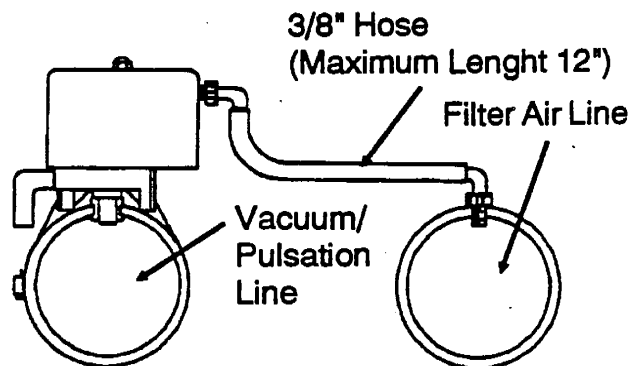

Figure 14

#### Vacuum Supply to Sampler

If sampler is used, a vacuum supply must be provided by means of a 3/16" I.D. hose. Drill and tap a hole for a nipple on a suitable vacuum line close to the meter. Use a 1/4" NPT x 3/16" barb nipple or similar. Use rubber cover to cap off nipple when sampler is not in use.

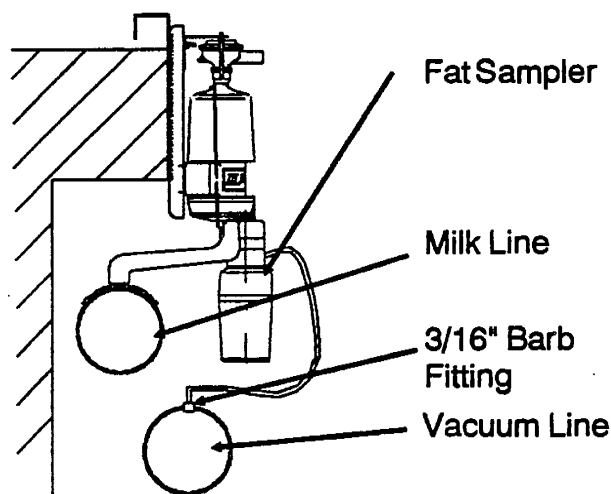

Figure 15



## B. QuadTrac Control

The QuadTrac control box comes with two clamps which bolt to the back of the box. These clamps enable the box to be mounted to a 1-5/8" vertical tube (See Figure 16 Item A).

Fasten two (2) 410448 Two-Bolt Tee Clamps to the upper and lower rails on the stall, (See Figure 16 Item B). On "S" Rail Parlors, recommended location for attachment is to the outer bend radius.

Install 6" x 1-1/4" Support Pipes in tee clamps and tighten, (See Figure 16 Item C). On some parlors it may be necessary to cut longer support pipes out of 1-1/4" pipe. Raise control box into position and fasten to 1-5/8" S.S. support tubes on control box with 410448 Two-Bolt Tee Clamps. (See Figure 16, Item D).

Connect all required wiring through the bottom of the control box using either 3/4" conduit or rubber cord with water tight connections. If using a Universal wiring harness a 3" conduit race way should be run over top of parlor and connecting to control box with flexible conduit.

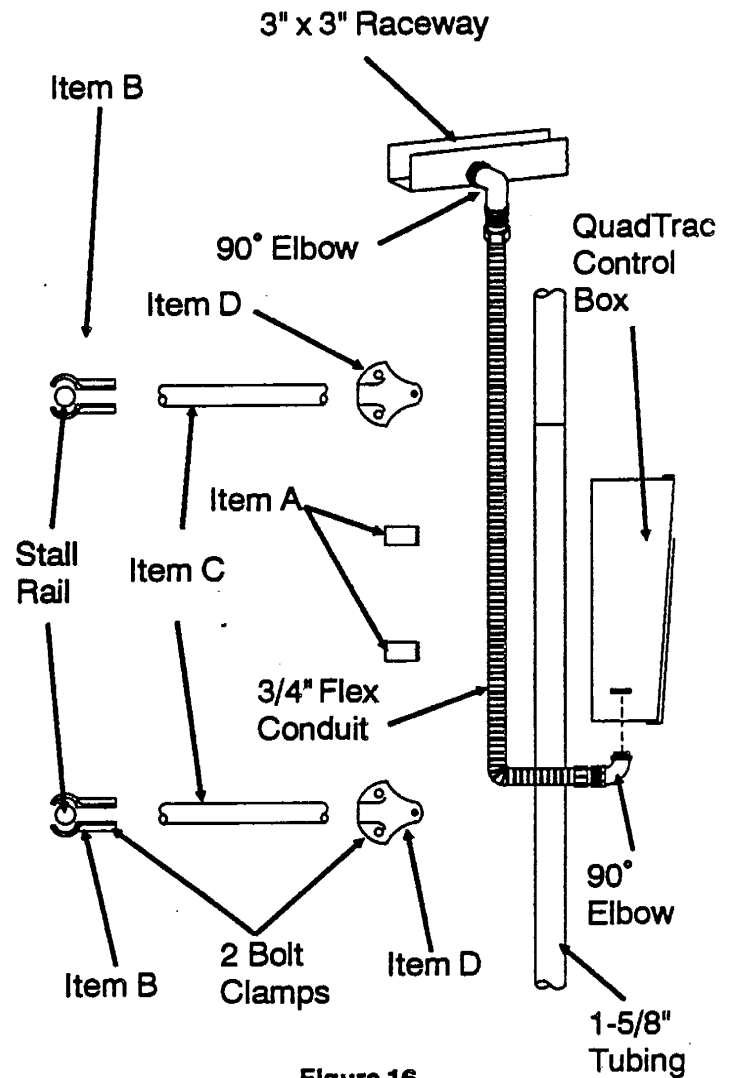

Figure 16

### C. Vacuum Cylinder

Mount the U-Channel mounting rail to the S-rails at the proper height using two 5/16" U-bolts, flat washers, and nuts provided.

If you are installing a S.S. cylinder, slide the 3" line clamps around the U-channel and S.S. Flex-O-Matic unit and secure with two S.S. thumb screws. Adjust the Flex-O-Matic cylinder so the bottom is approximately 24" - 26" above the cow floor. Tighten thumb screws securely.

If you are installing a plastic cylinder, first bolt the mounting rail bracket to the tabs on the cylinder, using four (4) 1/4" x 1/2" bolts with locking nuts. Next insert the mounting rail bracket into the U-channel, adjusting cylinder to the proper height (24" to 26" from cow floor), and secure in place using two (2) 1/4" x 1/2" bolts.

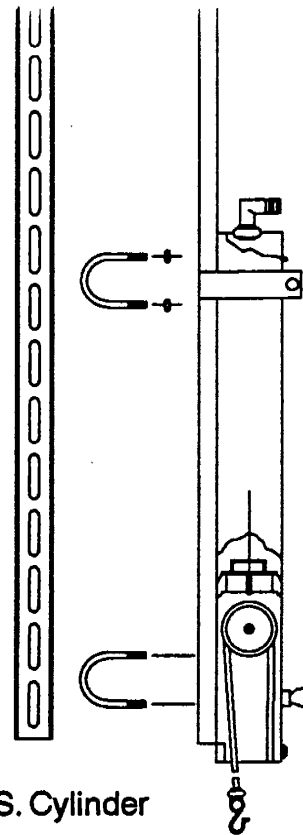

S.S. Cylinder

Figure 17

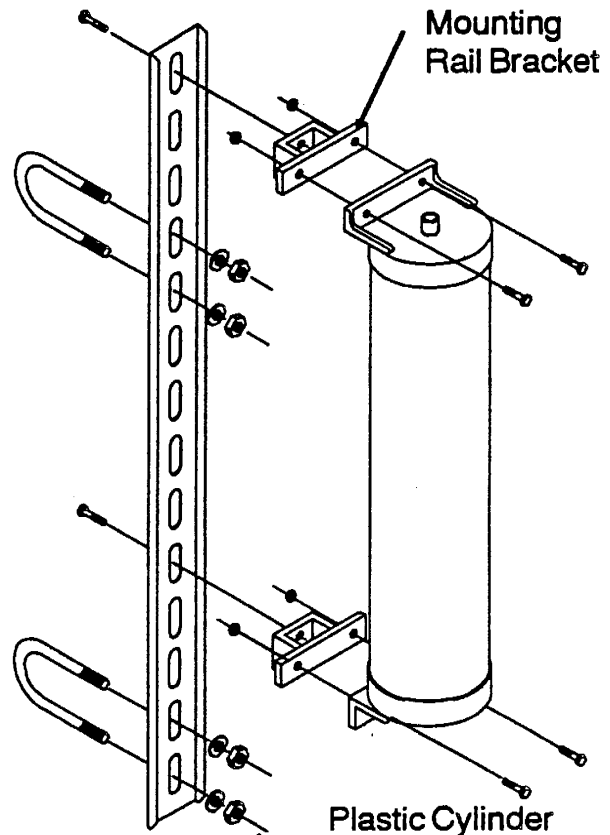

Plastic Cylinder

Figure 18

**D. Wiring**

The following diagram shows the principal way of wiring between the different devices and the QuadTracs:

If there is more than eight (8) QuadTracs, more transformers must be used. Depending on any extra power consuming devices, even more transformers must perhaps be used.

**1. Power Supply and Data Transfer**

To connect power and data transfer use a Universal wiring harness. Connect +,-,DS, and DR to +,-,DS and DR in the QuadTrac tracs. Then connect the + to + and the - to - on the ports on the bridges. If a computer is used connect also the DS to DS and DR to DR in the same way.

One transformer cannot be connected to more than eight (8) QuadTracs and every port cannot take more than three (3) QuadTracs.

Voltage Requirements	
Recomended DC Voltage	24.0 VDC
Maximum +20%	28.8 VDC
Minimum -10%	21.6 VDC

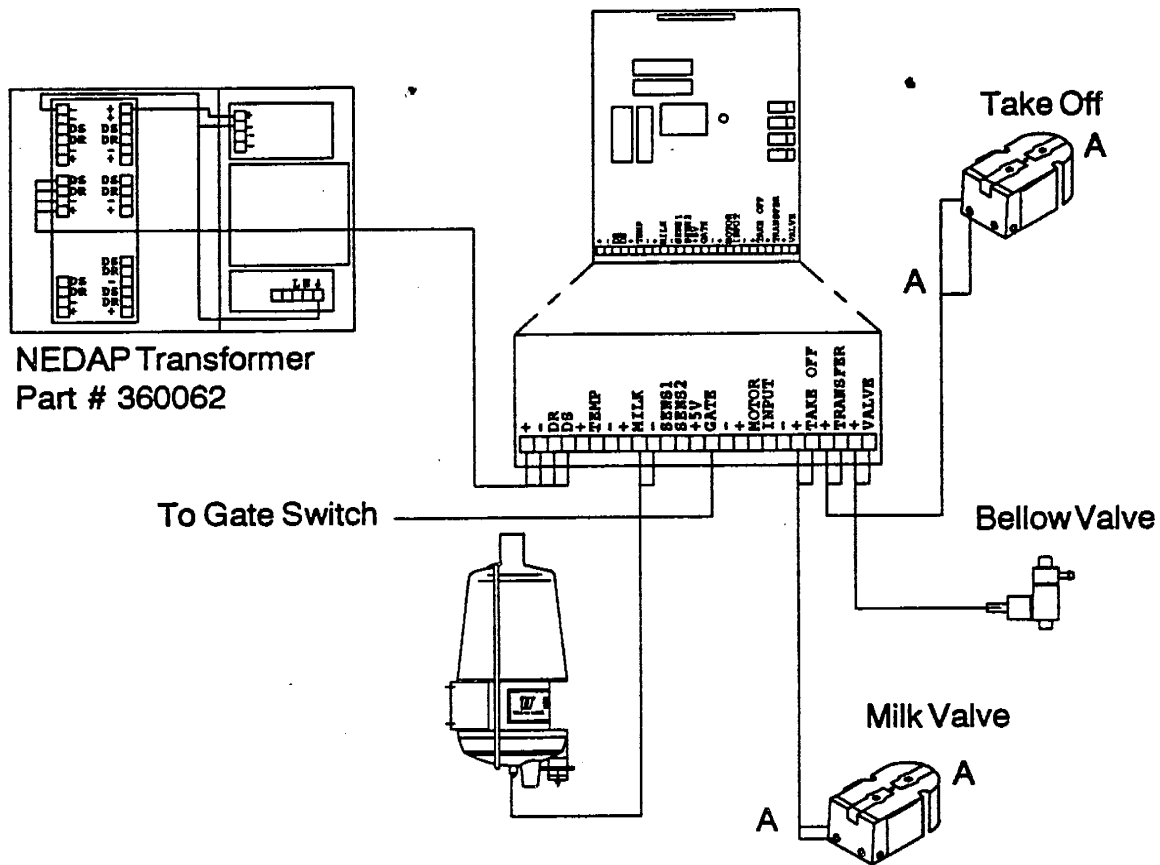

Figure 19

## 4. Reset Switch

For gate switch you can use a number of devices that reads the position of the exit gate. Check the wiring conditions for the device you choose to use.

Either an air switch connected to the pneumatic exit gate air line, or a limit switch or photo electric switch attached to the stall.

The switch must wire to the normally open terminals on the switch to the DC - on the QuadTrac power supply to the gate terminal on the QuadTrac board.

*See Following Schematic.*

The Gate Switch input on the QuadTrac board (s) performs four (4) function by either supplying a closed or open circuit for varying periods of time.

1. By creating a closed circuit for several seconds the QuadTrac board will transfer the milk weight to the computer, clear the existing milk weight from the display, and reset the QuadTrac for the next cow.
2. Creating a closed circuit for 10 minuetts (programmable) will cause the QuadTrac board to leave the milk program and enter the wash program.
3. Creating a closed circuit for one (1) hour in the wash cycle will put the units to sleep. (All displays go blank).
4. Creating an open circuit for five (5) seconds while units are asleep will wake the unit into the milk mode.

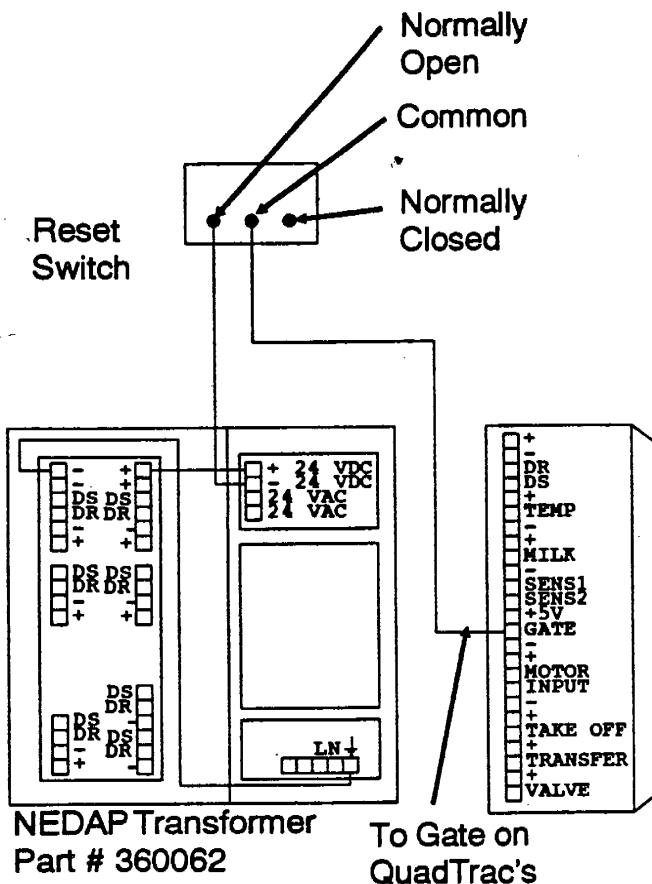

Figure 20

## NOTICE

*The gate wire can be wired to either the NO or NC terminal on the gate switch, depending on the location the switch is mounted in. During normal milking operation the gate circuit must be open.*

### 3. Wiring of Photo Switch

1. Connect the Blue and Brown wires from the photo sensor to the 24 volt AC connections on the QuadTrac power supply
2. Connect the Black wire from the sensor to one of the coil terminals.
3. Connect the other coil to the 24 volt AC terminal along with the Brown sensor wire.

4. Connect a wire between either the NO or NC terminal on Relay switch to the gate terminal on the QuadTrac board
5. Connect a wire from the 24 volt DC negative terminal on the power supply next to the common on the timer.
6. Connect a wire from the NC of the timer to the common on the sensor relay.

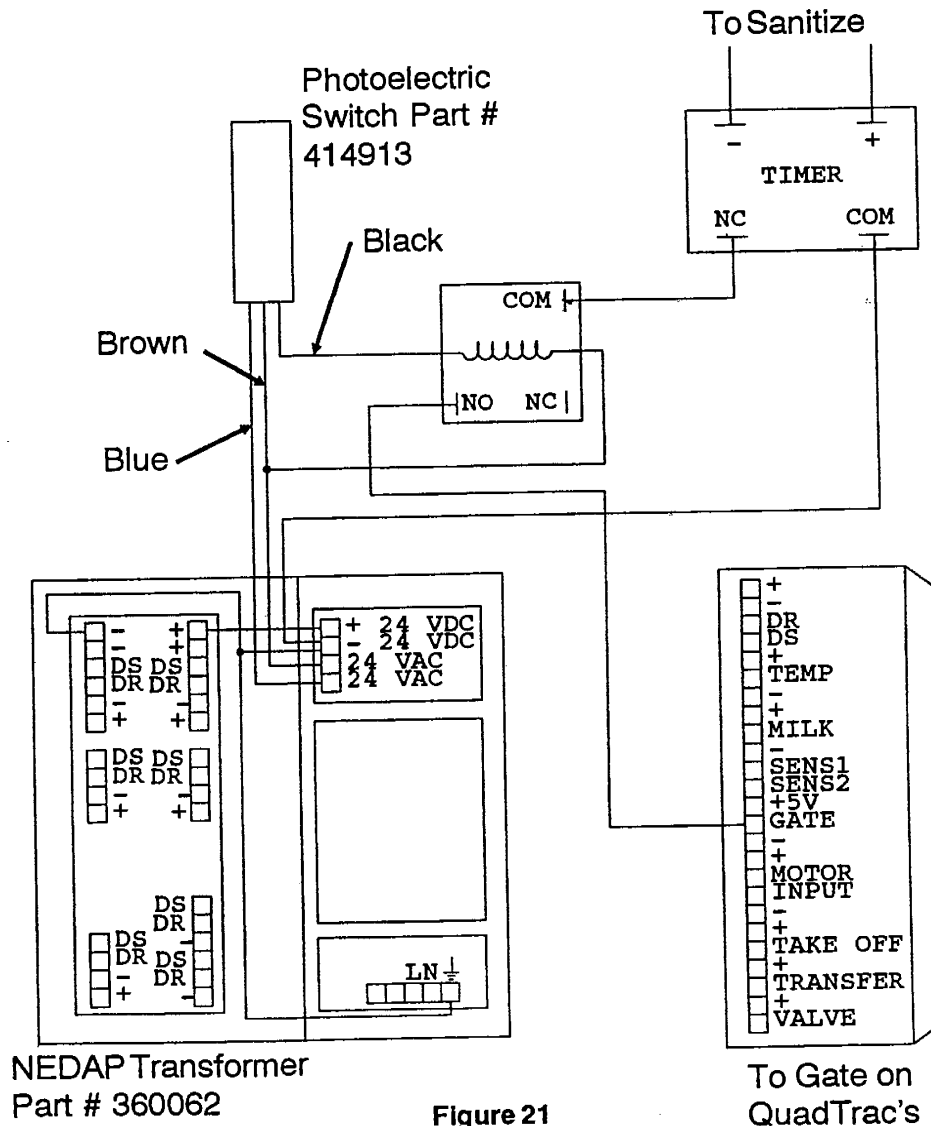

This example of the Photo Electric switch wiring show the gate being wired to the N/O Terminal. In this example the Photo Electric switch would be mounted at the top of the stall.

#### 4. Connection of Take Off and Milk Valve.

You can use either the vacuum operated milk valve or an air operated pinch valve.

For Milk Valve:

The take off cylinder and milk valve is operated via a Dual Air Valve (DP). Connect one of the DP's coil connections to the QuadTrac "Transfer" and + and the other to "Take Off" and +.

For Pinch Valve:

Connect "Take Off and + to the pinch valve and the "Transfer" and + to the DP operating the ReTrac and -.

#### Milk Meter Connections

Connect the reed switch cable from the meter to the QuadTrac's "Milk" and -.

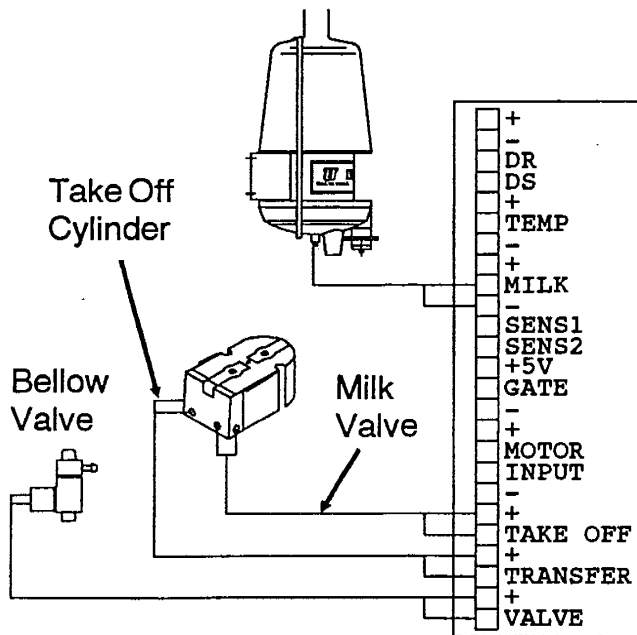

Figure 22

#### 5. Connection of the Bellow Valve

Use the provided contact block, open it by loosening the screw and push out the inside contact block. Connect two cables to the two holes situated opposite to one another on the contact block. Fix the contact block on to the valve using the provided screws, make sure the rubber gasket is in place between the block and the valve.

Connect the other end of the cable to the QuadTrac's "Valve" and +. Polarity does not matter.

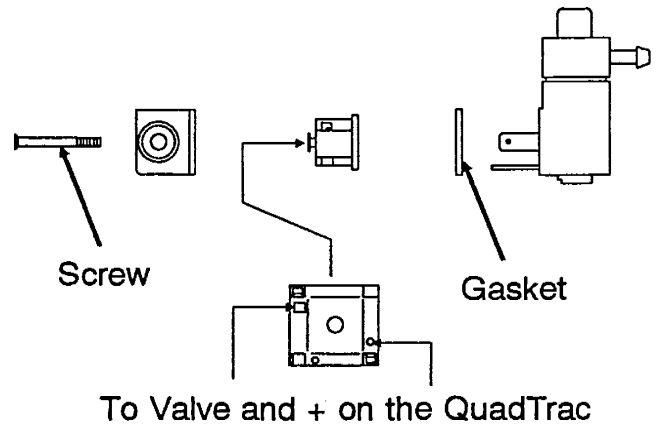

Figure 23

**CAUTION**

*Make sure when installing the wire cap that the wire connector point is either to the Right or Left and not straight up. Connector may fill with water causing a valve failure if connectors is installed in a vertical position.*

#### 4. Connection of Take Off and Milk Valve.

You can use either the vacuum operated milk valve or an air operated pinch valve.

For Milk Valve:

The take off cylinder and milk valve is operated via a Dual Air Valve (DP). Connect one of the DP's coil connections to the QuadTrac "Transfer" and + and the other to "Take Off" and +.

For Pinch Valve:

Connect "Take Off and + to the pinch valve and the "Transfer" and + to the DP operating the ReTrac and -.

#### Milk Meter Connections

Connect the reed switch cable from the meter to the QuadTrac's "Milk" and -.

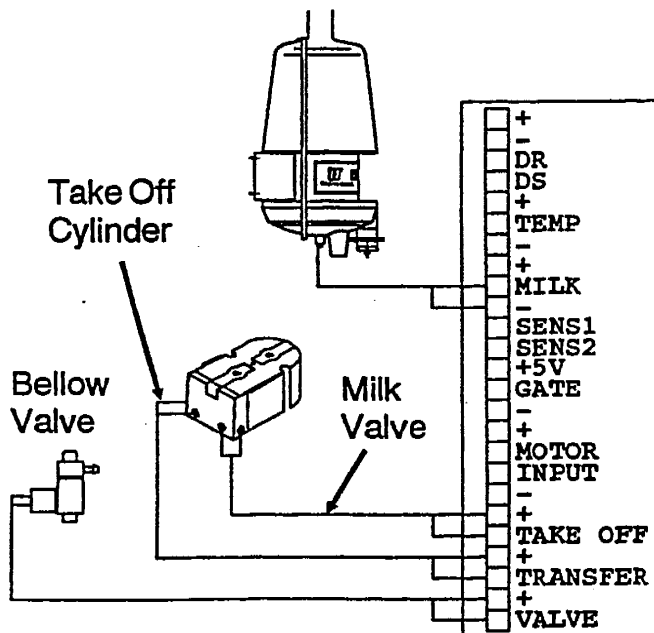

Figure 22

#### 5. Connection of the Bellow Valve

Use the provided contact block, open it by loosening the screw and push out the inside contact block. Connect two cables to the two holes situated opposite to one another on the contact block. Fix the contact block on to the valve using the provided screws, make sure the rubber gasket is in place between the block and the valve.

Connect the other end of the cable to the QuadTrac's "Valve" and +. Polarity does not matter.

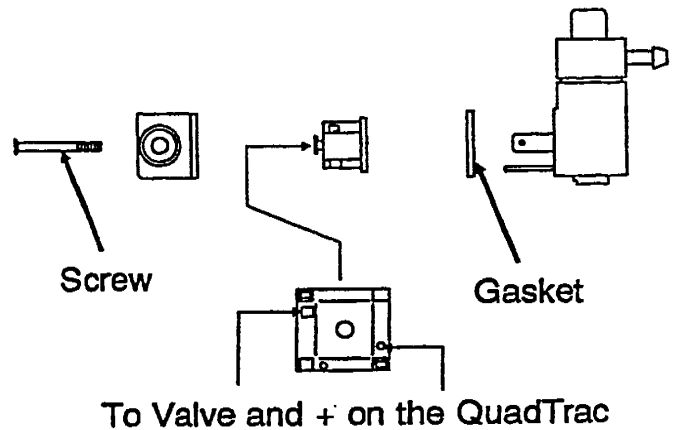

Figure 23

**CAUTION**

*Make sure when installing the wire cap that the wire connector point is either to the Right or Left and not straight up. Connector may fill with water causing a valve failure if connectors is installed in a vertical position.*

### 3. Wiring of Photo Switch

1. Connect the Blue and Brown wires from the photo sensor to the 24 volt AC connections on the QuadTrac power supply
2. Connect the Black wire from the sensor to one of the coil terminals.
3. Connect the other coil to the 24 volt AC terminal along with the Brown sensor wire.
4. Connect a wire between either the NO or NC terminal on Relay switch to the gate terminal on the QuadTrac board
5. Connect a wire from the 24 volt DC negative terminal on the power supply next to the common on the timer.
6. Connect a wire from the NC of the timer to the common on the sensor relay.

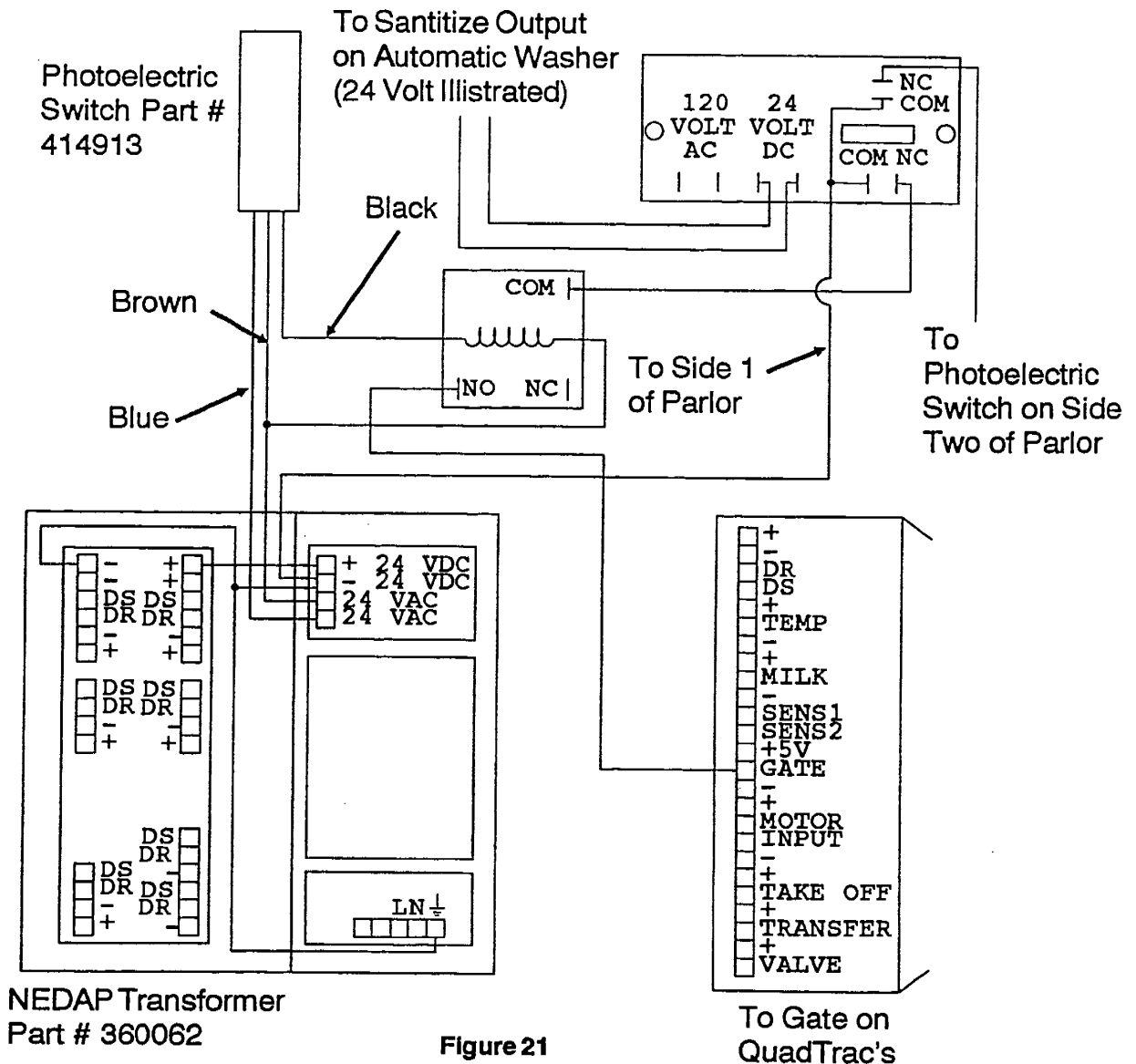

Figure 21

This example of the Photo Electric switch wiring show the gate being wired to the N/O Terminal. In this example the Photo Electric switch would be mounted at the top of the stall.



## II. Programming:

The QuadTrac has a set of parameters that can be changed to fit the needs of the farm. The parameters are to be found in the service program. To enter the service program push "Illness" "E" "9" "Milk". To leave service program push "Reset". You step through the parameters by pushing "E" or "Illness". Change parameters by pushing "C" and a new numerical value. To accept what you entered push "E". Continue to step with "E" or "Illness".

Usage Symbols	
A	Must be adjusted at Start up
B	May be adjusted to needs of Farm and Equipment installed
C	Not normally used or adjusted
D	Should not be adjusted, unless instructed to do so by a Universal Representative.

Service Program Parameters And Default Values				
Program Sequence	Program	Usage	Program Description	Default Values
1	VPMCF03C		Program name and version number.	
2	STDALO	A	Stand alone mode Yes or No	N
3	ADDRES	A	Address of the QuadTrac.	00
4	ADDRS2	C	Second address used in swing-over mode, when not using swing-over mode always enter 00.	00
5	LANG	A	Language, 0=English, 1=Dutch, 2=French, 3=German, other values are equal to zero. If 4 is entered the language is English but the milk yield, ave. milk yield and the maximum milk yield will be shown and calculated in pounds, the conversion factor is 2.205	0
6	SCREEN	B	Time period (seconds) how long the cow information is showed on the display when a function key is pressed. (0-99)	05
7	GATE	B	Time period (seconds) between the switching of the gate switch and registration of it by the microprocessor. (0 means 0.5 sec.)	01
8	CLTIME	B	Cleaning Time (minutes), time between opening of the gate and changing the state of the QuadTrac to cleaning.	10
9	OFFS	C	Offset, basic value of the milk measuring chamber.(0-255 gram)	153
10	FACT	D	Factor, water/milk conversion value.	103
11	TEST	C	Basic value for meter control with water. (0-255 gram)	186

**Service Program Parameters And Default Values**

<b>Program Sequence</b>	<b>Program</b>	<b>Usage</b>	<b>Program Description</b>	<b>Default Values</b>
12	CALIBRATE	B	Press C-key for starting calibration of the milkmeter (for calibration procedure see next paragraph)	
13	NEUT	B	Let Down time for QuadTrac control. (0-180 sec.)	0120
14	STRP	B	Milk time for QuadTrac control.	0015
15	DLY	B	Take Off delay time for QuadTrac control.	2000
16	FLVL	B	Flow level, threshold detection level for milk flow rate used for QuadTrac control. (0-400 gram/min.)	0300
17	KFAC	B	Kick-off multiply factor, programmable from 0-9.9 in steps of 0.1	40
18	KLVL	B	Kick-off minimum flow rate level, programmable from 0-9999 grams.	1000
19	CLNP1	B	Cleaning phase 1, total time 1st washing phase. (0-99 sec.).	15
20	CLNP2	C	Cleaning phase 2, total time 2nd washing phase. (0-99 sec.).	10
21	CLNP3	C	Cleaning phase 3, total time 3rd washing phase. (0-99 sec.).	10
22	STDBY	B	Standby time, total time QuadTrac remains in cleaning position. (0-99 min.)	60
23	REED	D	Inactive reed contact time. (0-9999 msec.)	0200
24	FEEDM	C	Feed portion provided by one turn of the feed motor. (0-999 grams, calibrated value) If feed portion is equal to zero, the motor output can be used as attention output.	000
25	FDDL	C	Feed delay time. (0-99sec)	00
26	MOTOR	C	Using feed motor Yes or No. see 5477	N
27	MOTREQ	C	Motor request, when using motor output enter Yes.	N
28	MSPD0	D	Milk correction factor, milk flow rate 0-1 kg/min.	26
29	MSPD1	D	Milk correction factor, milk flow rate 1-2 kg/min.	31
30	MSPD	D	Milk correction factor, milk flow rate 2-3 kg/min.	236
31	MSPD	D	Milk correction factor, milk flow rate 3-4 kg/min.	339
32	MSPD	D	Milk correction factor, milk flow rate 4-5 kg/min.	442
33	MSPD5	D	Milk correction factor, milk flow rate 5-6 kg/min.	50
34	MSPD6	D	Milk correction factor, milk flow rate 6-7 kg/min.	57
35	MSPD7	D	Milk correction factor, milk flow rate 7-8 kg/min.	62
36	MSPD8	D	Milk correction factor, milk flow rate 8-9 kg/min.	67
37	MSPD9	D	Milk correction factor, milk flow rate 9-10 kg/min.	72
38	MSPDA	D	Milk correction factor, milk flow rate 10-11 kg/min.	77
39	MSPDB	D	Milk correction factor, milk flow rate 11-12 kg/min.	82
40	MSPDC	D	Milk correction factor, milk flow rate 12 kg/min.	87

**SECTION M**

Universal<sup>®</sup> Dairy Equipment, Inc.  
11100N. Congress Ave.  
Kansas City, Missouri 64153

Issued 4/96

**Service Program Parameters And Default Values**

<b>Program Sequence</b>	<b>Program</b>	<b>Usage</b>	<b>Program Description</b>	<b>Default Values</b>
41	MSPDD	D	Milk Flow Calibration, correction rate used for calculating the offset value.	39
42	VAL0	D	Discharge valve opening time at milk flow rate 0-1 kg/min.	0400
43	VAL1	D	Discharge valve opening time at milk flow rate 1-2 kg/min.	0400
44	VAL2	D	Discharge valve opening time at milk flow rate 2-3 kg/min.	0400
45	VAL3	D	Discharge valve opening time at milk flow rate 3-4 kg/min.	0400
46	VAL4	D	Discharge valve opening time at milk flow rate 4-5 kg/min.	0400
47	VAL5	D	Discharge valve opening time at milk flow rate 5-6 kg/min.	0400
48	VAL6	D	Discharge valve opening time at milk flow rate 6-7 kg/min.	0400
49	VAL7	D	Discharge valve opening time at milk flow rate 7-8 kg/min.	0400
50	VAL8	D	Discharge valve opening time at milk flow rate 8-9 kg/min.	0400
51	VAL9	D	Discharge valve opening time at milk flow rate 9-10 kg/min.	0400
52	VALA	D	Discharge valve opening time at milk flow rate 10-11 kg/min.	0400
53	VALB	D	Discharge valve opening time at milk flow rate 11-12 kg/min.	0400
54	VALC	D	Discharge valve opening time at milk flow rate 12 kg/min.	0400
55	VALD	D	Discharge valve opening time during calibration and water test.	0650
56	INVVLV	A	Inversion of milkmeter valve output.	Y
57	INVATO	A	Inversion shut off "take off" output must be set to yes	N
58	FKEYS	B	Function key, enable or disable function keys.	Y
59	RTMP	B	Resistant value of temperature sensor, when using temperature measuring, put in the value of the ntc-resistant. When no value is known, fill in 5725.	0000
60	TEMP	B	Actual measured temperature	00.0

**Service Program Parameters And Default Values**

<b>Program Sequence</b>	<b>Program</b>	<b>Usage</b>	<b>Program Description</b>	<b>Default Values</b>
61	CONATT	B	Conductivity attention Yes or No, used for motor out-put attention in case of conductivity attentions during current or previous milk session. The motor output, if using no feed motors, will not be activated after the ACR cycle in case of a conductivity attention	N
62	CONDOC	B	Conductivity, when using conductivity measuring fill in Yes. After filling Yes and pressing the E-key, the actual conductivity value of each quarter is shown.	N
63	INVMTR	C	Invert motor output, only when used as attention output.	N
64	DEFAULT	A	Getting back the factory default values when entering Yes and power down and power up the QuadTrac. Use the fuse in the QuadTrac to do this.	N

### III. Start Up

When all the connections are done the power can be turned on. The QuadTracs should light up and show : All segments, all lights, RAM TEST, OK, ROM TEST, OK, WATCHDOG, OK and then CALIBRATE, in this order.



All four (4) display lights come on

R A M T E S T

R A M O K

R O M T E S T

R O M O K

W A T C H D O G

O K

C A L I B R A T E

Next do a manual enter of all the default values. This also is a Ram Clear procedure to insure that no old programming values are still in the memory.

Enter service program on all the QuadTracs and enter the defaults — push "Illness", "E", "9" and "Milk". Then push "Illness", "C", "1" and "E" in this sequence (See Figure 24).

When this is done to all the QuadTracs, power down the system for a couple of seconds and then power it up again.

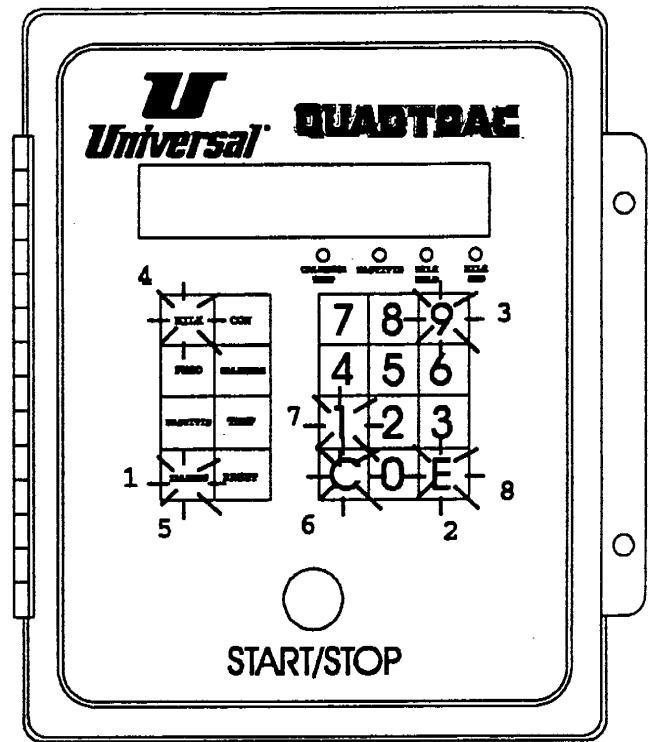

To set defaults, push above button in the numerical sequence shown on the display

Figure 24

Next Re-enter the program mode and enter all numeric values (all items on the program chart indicated with a "A").

1. To enter program Press the four corner buttons starting with "Illness", then "E", "9" and "Milk".

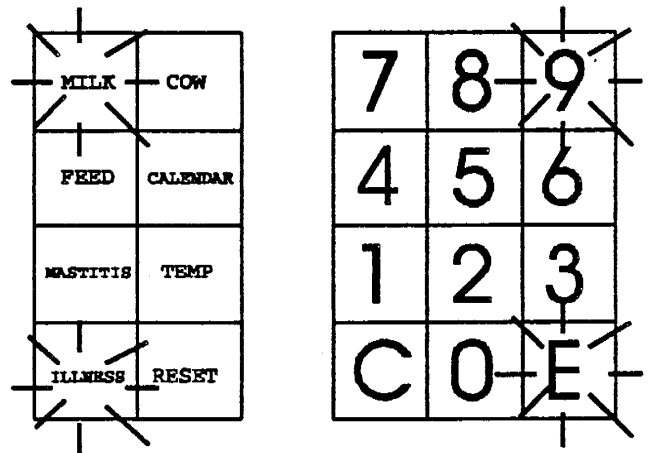

When first entering the program mode the display will show the Prom Number, which is Function Number 1.

V P M C F 0 3 0

To move to a program function with a higher numerical value, Press the "E" Button.



To move to a program function with a lower numerical value Press the "Illness" Button.



After reaching the program function you wish to change Press the "C" button to clear out current values.



The Display will begin to flash and the value segment(s) will go blank with a underline. Example:

A D D R E S \_ \_

Press the proper numerical key to display the desired value. Display will show the new value and continue to flash. Example:

A D D R E S 1 2

Press the "E" Button to enter the new value into the program.



The display will stop flashing and display the new value in program.

A D D R E S 1 2

Press either the "Illness" or "E" button to select the next program function you wish to change. "E" will move you to a higher program function and "Illness" will move you to a lower program function.



To leave the program mode and return to operation Press "Reset"



## NOTICE

*The illustrations on this page are examples only to illustrate how to program and are not part of the set up procedures.*

The "LED" may return to several different displays depending on how QuadTrac is set up.

If being used as a stand alone unit the display will show "COW" followed by four zeros.

C O W 0 0 0 0

If used with a computer but there is no communication between the QuadTrac and the computer the display will show "Calibrate"

C A L B R A T E

It used with a computer and there is communication between the computer and the QuadTrac the display will show "COW Question Mark".

C O W . . . . ?

## NOTICE

*You can also enter the program mode while milking a cow. The QuadTrac will continue to tally the milk weights and will add the weight to the display upon exiting the program mode. However, while in the program mode the QuadTrac remains in a manual mode and will not detach the unit automatically.*

— If the program was entering during a milk cycle the display will return to the Milk Display.  
Example:

M I L K . 1 5 . 4

### ORIGINAL SETUP PROCEDURES.

Next Re-enter the program mode and enter all numeric values (All items on the Program chart indicated with a "A").

1. To enter program Press the four corner buttons starting with "Illness", then "E", "9" and "Milk".

The following program functions should be set before starting the first milking. With the washer in the program mode follow the steps detailed below.

#### 1. Function #3.

Enter unique addresses to all the QuadTracs. This is so the wash cycle for the meters won't coincide.

Press "E" or "Illness" until you reach Address

A D D R E S 0 0

Press "C" to clear value.

Press numerical numbers to display correct address number.

Press "E" to enter new value in program.

#### 2. Function #5

Language

L A N G . . . . 0

Press "E" or "Illness" until you reach Language

Press "C" to clear value.

Press numerical number corresponding to the language used.

Press "E" to enter new value into program.

3. function #5/

Invert Milk Value

I N V A T O N

Press "E" or "Illness" until you reach  
I N V A T O

Press "C" to clear value.

Press numeral button #1 to change  
from no setting to yes

Press "E" to enter new value into  
program.

4. Function #2

Stand Alone

S T D A L O N

Press "E" or "Illness" until you reach  
S T D A L O

Press "C" to clear current value.

Press 1 = yes for stand alone; 0 = no  
for use with computer.

Press "E" to enter new value into  
program. If the QuadTrac was  
programmed to yes for stand alone, the  
display will automatically go to COW  
0000 when the "E" button is pushed.

C O W 0 0 0 0

The remaining functions may be changed if  
desired, however the QuadTrac will operate  
properly with all other functions left at the  
default settings. For an overview of  
programs you may wish to change, review the  
program chart on pages 25-28. Note all  
program functions identified with a "B" in the  
usage symbol column.



#### IV. Customizing of QuadTrac

The following is a list of programs which control the Take Off functions of the QuadTrac which may need to be changed to fit the equipment installed or the customers needs.

Take Off Functions					
Program Sequence	Function	Program	Purpose	Range	Recommended
13	Let Down Delay	NEUT	Adjust to allow adequate time for cows to start letting down milk	0-180 sec	60-90 sec
14	Milk time	STRP	Amount of time from end of milk flow to vacuum shut off	0-180 sec	10-20 sec
15	Take Off Delay	DLY	Amount of time from when vacuum shuts off until unit detaches	0-999 ms	1500-2500 ms
16	Milk Flow Rate	FLVL	This sets the end of milk threshold using the milk meter as the sensor. The setting range is 0.1 to 0.8 lbs. per minute in 0.1 lb per minute increments. The typical setting is 0.5 to 0.6 lbs. per minute. Note: 28.35 grams = 1 ounce 45.36 grams = .1 pound	0-400 grams/min	225-300 grams/min

To set these values, follow the same procedures for each program as used in the Start Up settings.

Press "E" or "Illness" until you reach the correct program

Press "C" to clear.

Press the numerical keys to enter the corrected values.

Press "E" to enter the new value into the program

Press "Reset" to leave programming and return to operation.

## IV. Calibration

### A. Setup

When all equipment is in place and working under normal condition the meters should be calibrated.

## NOTICE

*It is important that the conditions, while calibrating, are exactly the way it is going to be in the future i.e. vacuum level, hose length etc. must not be changed after calibration is done. This would require a new calibration.*

For a correct calibration you need the following equipment:

- A milk bucket and lid with two nipples min O.D. 7/8". If nipples are smaller, hose clamps can be used to fit the hoses on the nipples.
- A pail with a minimum capacity of 3 gallons.
- Rubber tube I.D. 5/8" to connect milk meter and milk bucket (if possible, use the already installed milk tube from milk meter to milk line).
- Rubber tube I.D. 5/8" for connection between milk bucket and milk line.
- Rubber tube I.D. 5/8", length 5' for connection between test pipe and milk meter.
- Calibrated test equipment for a water flow of 3,7 kg/min and air bleed of 7 liters/min. Use test kit PN 313365.
- Scale indicating at least every 0.02 pounds.
- Two hose closing devices e.g. hose clips, to go on hose between bucket and milk line and on hose between meter and test pipe.

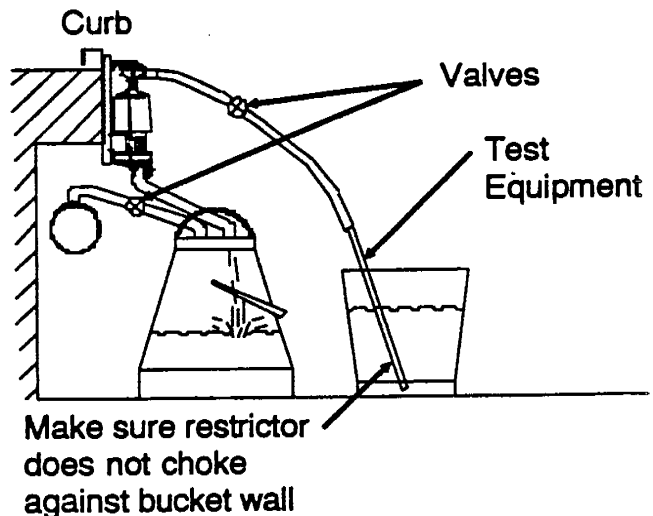

Figure 25

### Alternative Calibration Setup.

Instead of collecting the water in a catch pail, run the required number of dumps of water through the meter in the regular milking setup and determine the weight metered by subtracting the difference of water in bucket. First weigh the pail with water (minimum 15Kg. required) then run the calibration test (50 dumps) and then re-weigh the pail and subtract the difference. This is the value which would be entered into the QuadTrac. Repeat this procedure for each of the three (3) calibration tests. (See Following Example).

1. Weigh bucket of water.	15.63Kg
2. Run 50 dumps of water through meter per instructions.	—
3. Weigh bucket of water.	6.32 Kg.
4. Subtract difference.	9.31Kg.
5. Enter this value in the QuadTrac per step 12	

## B. Milk Meter Calibration Procedures:

Before you start calibration

- The Milk bucket must be completely empty and take a note on how much it weights empty.
1. Open all gates (gate switches closed). This will clear all units and set the milk weights to zero. Exit gates must remain open during the entire calibration procedure.
  2. Enter the Service program by, pressing the buttons "Illness", E, 9 and "Milk" in that order.
  3. Press the "E" or "ILLNESS" key until field "CALIBRATE" is displayed.

C A L I B R A T E

4. Press "C-key", and

C A L V A L

will appear on the display

5. Enter the number 3 or the number of samples you wish to run.

C A L V A L 3

6. Press the "E" key to enter number and the display will show .

C A L 3 0 0

This will set the program to average the calibration over 3 calibration tests.

7. Fill the water bucket with 3 gallons of water.
8. Vacuumize the receiving bucket by opening the valve going to the milk line.

## NOTICE

*Vacuumizing the receiving bucket should only be done immediately before you are ready to begin flowing through water i.e. opening the valve to the bucket with water. Otherwise the meter could empty an extra dump down to the receiving bucket.*

9. Open the valve on tube going to the bucket with water and draw water through the meter.

Make sure the restrictor does not choke up against the bucket wall. The display counts the dumps during the calibration.

10. Stop the calibration after 50 dumps.

C A L 3 5 0

If more dumps are let through there's no catastrophe but try to keep it to 50 and it is easier to recognize any unusual values on the scale.

11. Weigh the water in the receiving bucket which past through the meter.

Normal values on the scale is between 9.05kg and 9.55kg for 50 dumps. In case of other scale values check the meter visually for any leaking valves or other problems disturbing the operation.

## NOTICE

*Some scales can show kilogrammes directly (check your scale and change to this mode). If you can't read kg on your scale multiply the pound reading with 0.4536 and enter by you got.*

12. Press the **E**-key and the LED will display blanks.

C A L 3 \_ \_ \_ \_

Enter the scale value in kilograms, e.g. 943 means 9.43 kg of water.

C A L 3 \_ 9 . 4 3

13. Press the **"E"** and the display will now show the average flow rate for this test.

F L W R T 0 3 . 8

If the flow rate is not within plus or minus 0.2 kg/min of 3.7 kg/min check vacuum and test pipe and start all over again (push Reset key and start from pos. 2 again). If another flow is used the calibration can't be trusted and the calibration is useless. If you can't get a proper flow just leave the meters uncalibrated until you have good equipment.

14. Repeat the procedure from number six (6) the second time by pressing the **"E**-key" again. The display will now read.

C A L 2 \_ \_ \_ \_

Allow 50 dumps of water through the meter.

C A L 2 \_ \_ 5 0

Press **"E"**

C A L 2 \_ \_ . \_ \_ \_

Enter the weight of water run through meter.

C A L 2 \_ 9 . 1 3

Press **"E"** and the flow rate for this test will be displayed.

F L O R T 0 3 . 6

15. Repeat the procedure from number six (6) a third time by pressing the **"E**-key" again. The display will now read.

C A L 1 \_ \_ \_ \_

Allow 50 dumps of water through the meter.

C A L 1 \_ \_ 5 0

Press **"E"**

C A L 1 \_ \_ . \_ \_ \_

Enter the weight of water run through meter.

C A L 1 \_ 9 . 4 3

Press **"E"** and the flow rate for this test will be displayed.

F L O R T 0 3 . 7

16. When the last calibration is done, pressing the **"E**-key" will show the average measured flow rate of all three (3) tests in kg/min.

F L W R T 0 3 . 7

17. Press the **"E**-key" again and the program goes back to the Service/Calibration program again.

C A L B R A T E

18. Check the new **"OFFSET"** and **"TEST"** values. These are automatically calculated by the program when calibration is done.

Offset and Test are program functions number 9 and 10 on the QuadTrac.

Press **"ILLNESS"** until you reach offset.

O F F S \_ \_ 1 5 1

## SECTION M

The onset value should be in the range of 148 - 158. If not You might have a problem, please check:

- That all springs inside meter is in position,
- That no straw, hair or other alien material is obstructing operation of meter,
- Possible vacuum leakage. (Check rubber seals, bellow and hoses in meter.)
- Tightness of outlet valve in the milkmeter. Do as follows:

Fill the measuring chamber with just enough water so that the float does not float up and cause a dump. Now check under the outlet valve if there is any dripping. There is always some dripping from water sitting on surfaces under the valve and on the guide pins but after a while all dripping should stop.

If there is a leak, take the meter apart and check for dents or dirt on the sealing surface on the valve or valve seat. If nothing is detected, put the meter together again and check if it's still leaking. If so change to a new valve.

- Reed switch level(use gauge or calipers). Do as follows:

Take off the inlet chamber and inlet valve and put them aside. Take also off the black conical shaped weight on top of float.

The float should be within 29.5mm to 30.5mm under the top surface of outlet valve when reed switch is switching. With calipers check if float is activating the dump valve within this range or...

With gauge slide it on the outlet valve with black O-ring down. Lift float up so it touches the gauge. The dump valve shouldn't activate. Turn the gauge with O-ring facing up and lift float. Now the dump valve should activate.

If it activates any other way the reed switch need to be pushed up or down. Use the Allen wrench, on the gauge, to loosen the grub screw, holding the reed switch pin, and push the pin up or down. Repeat until switching is within range.

19. To exit the Service program,  
Press the Reset button.

## NOTICE

*All values shown in the calibration procedures in this manual are examples only. These values will vary during an actual meter calibration.*

To confirm a good calibration, the milk meter can be checked with a so called "water test".

For a correct water test you need the same equipment as for calibration hooked up in the same way.

**Before you start the water test**

- The milk bucket and milk meter must be completely empty.

To start the water test, open all gates (gate switch closed)

1. Press the buttons below in a rapid succession:

"COW " "E "

"CALENDAR " "E "

"TEMP " "E "

the display will show:

**T E S T 0 0 . 0 0**

2. Draw approximately 10 kilograms of water through the meter.
3. Stop the water test when the display shows 10 kg.

**T E S T 1 0 . 0 0**

4. Weigh the water which passed the meter and compare it with the value of the display. Write down the value of the display, the scale and the difference between those.

5. After the water test, press the "E-key".

**F L W R T 0 2 . 4**

The average flow rate will be displayed in kg/min.

Press the "E - key" a second time and the

**T E S T 0 0 . 0 0**

displayed value will be reset and the procedure can be restarted.

6. Repeat the procedure a second time.
7. If the average of the two compared water values are within the 200 grams limit, the water test is OK, if not make a new calibration.
8. During the water test, the "OFFSET" and "TEST" value can be displayed by pressing the "C-key". Press the "C-key" one time to display offset value.

**O F F S 1 5 1**

Press the "C-key" a second time to display the test value.

**T E S T 1 8 5**

9. To exit the water test program, just press the "RESET" button. The

**C L E A N**

display will return to a clean because the gate switch is still closed.

Closing the exit gates, (opening the gate switch contacts) the display will return to normal operation.

## VI. Service

### A. QuadTrac

The QuadTrac control unit requires little servicing after the original installation is completed. Following are several items which should be checked or serviced.

1. Check and replace decal if any cracks appear.
2. Check for proper incoming voltage (21.6-288.8 volts DC).
3. Check for all wire connections and box for moisture.

### B. UniFlow

There are several items on the UniFlow meter which should be serviced or checked on a regular schedule.

#### 1. Meter Valves

Both the inlet and outlet valves should be checked for proper settings. If these valves fail to seat properly and leak, the operation of the meter can be affected, and the valves should be replaced.

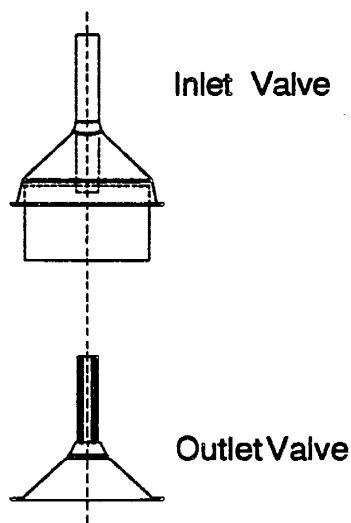

Figure 26

- If the inlet valve leaks, not only can the milk weight be affected, but if the leak is large enough the meter may fail to pump.
- If the outlet valve leaks, not only can the milk weight be affected, but if the leak is large enough the meter may fail to dump.

#### 2. Bellow Valve repair

The bellow valve at the top of the inlet chamber should be replaced yearly and checked for leaks every 6 months. A leak can cause the inlet and outlet valves to open and close slowly affecting the milk weight. A crack will also allow milk to leak into the bellow air valve causing it to fail.

To replace bellow diaphragm, loosen the screw on the bellow valve guide. (Do not completely disassembly.) Remove old diaphragm and slip new diaphragm over guide assembly and make sure diaphragm rib is seated in the groove of the guide. Tighten screw and reassemble in inlet chamber.

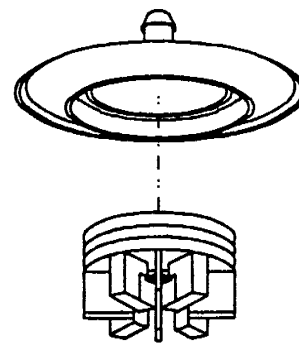

Figure 27

The bellow valve is also part of the service kit (PN 630027) which also includes all rubber parts in the meter. Universal recommends servicing all meters every 12 months.

### 5. Reed Switch Replacement

When replacing a reed switch it is important that the switch is set at the proper height in the outlet chamber.

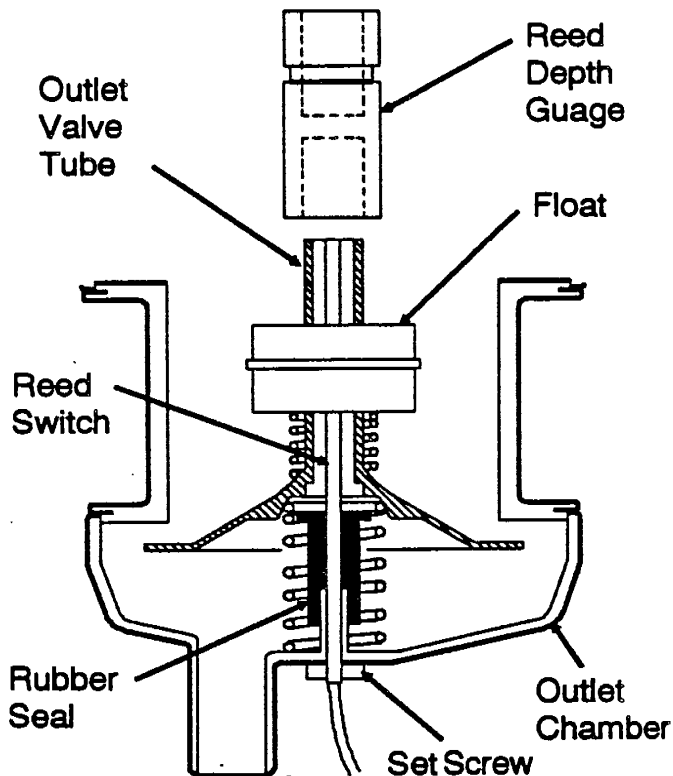

Figure 28

- a. First remove the outlet chamber from the meter by unsnapping the lower clamp.
- b. Remove the rubber seal from around the reed switch (sensor). This will make it much easier to adjust the reed switch to the proper setting.
- c. Loosen the allen set screw and remove old sensor and replace with new one. Adjust to the same height as old sensor and snug set screw
- d. Reassemble the outlet chamber to the meter less the rubber seal.

e. Remove inlet chamber from top of meter along with the inlet valve and float weight.

f. Connect the two wires from the sensor to a ohm meter.

g. Slide the reed depth gauge over the outlet valve tube with the grooved portion of the gauge down. Move the float up and down between the bottom of the outlet valve and the depth gauge. At no time should the Reed switch create a closed circuit. If it does make a closure, the reed switch must be adjusted up, or higher in the outlet chamber.

h. Next reverse the depth gauge so the grooved portion is up. Move the float up against the bottom of the gauge and the reed switch should make a closure. If no closure is created the reed switch is too high and must be lowered in the outlet chamber.

i. After the reed switch has been adjusted properly, tighten the set screw, disassemble the bottom and re-install the reed switch seal.

j. Completely re-assemble meter, making sure all springs and valves are seated properly and meter is ready to operate.



## VII. Trouble Shooting

When starting up the system for the first time you may encounter problems related to wrongful wiring and/or broken boards and other devices.

Always check wiring and fuses and bring extra QuadTrac mother boards.

When nothing else works try changing the parts you think are bad.

When Starting Up		
Symptoms	Cause	Cause/Action
Some of the QuadTrac's wont start when powering up.	No power to units.	Check fuses. Check wiring. Change board.
The fuses burn when powering up.	Bad wiring or bad components.	Check wiring. Disconnect all valves and wire back on one at a time till fuse burns, change broken device.
Some meters do not react to opening/closing the exit gate as the others do.	Negative on QuadTrac board not connected to Negative on power supply.	Make sure power supply to all QuadTracs has identical negatives. Connect all negatives together in transformers.

Other Trouble Shooting Guides			
Problem	Malfunction	Cause	Solution
Milk meter is overestimating	Air-bleed is blocked	Air-bleed in milk meter is blocked	Clear hole
		Air-bleed hole in milker unit is blocked	Clear hole
	Inlet valve ring has fallen off		Replace inlet valve
Milk meter is not responding as normal, changed functions in service program or new values	Electronics are jammed	Parameters in service program changed due to peak voltage	Disconnect the power supply for a few minutes. Check the installation for diodes and disturbance protection units
Milk meter is not responding to some key functions and display is flashing: CALIBRATE	Unproper address		Insert a proper address
	No communication		Check the cabling for breaks. Is it a computer failure?

**Other Trouble Shooting Guides**

<b>Problem</b>	<b>Malfunction</b>	<b>Cause</b>	<b>Solution</b>
Milk meter in not responding to some key functions and display shows nothing else			See "QuadTrac is not responding to key signals"
QuadTrac is not responding to key signals	Electronics are jammed		Disconnect the power supply for a few minutes. Check the installation for diodes and disturbance protection units
	PCB is broken		Change PCB
Milk meter does not count and flows over	Float stuck	Grain of sand or cow hair	Dismantle inlet chamber and inlet valve and make float free
	Sensor not switching		Change sensor
	Sensor switching		See "QuadTrac is not responding to key signals"
	Float in upper position, Water in measure chamber		Check vacuum level during cleaning
Milk meter counts only 0.4 to 0.5 lbs. and flows over	Bellow valve not functioning	Bellow valve dirty	Clean bellow valve
		Bellow valve clean	Replace bellow valve
Milk meter counts 0.4 to 0.5 lbs. and is leaning a lot	Unproper milk meter valve kit movement	Unproperly assembled valve kit	Reassemble valve kit
		Unproperly fixed valve spring	Put spring in proper position
Milk meter is underestimating	Leakage in inlet or outlet valve		Replace valve
	Total air-bleed from milker unit to big	Liner slip	No action
		leakage in liners, tubes, tip-top valve, and take-off valve of the cluster	Replace faulty details
	Valve kit is not moving properly	Leaking bellows	Replace bellows
		Collapsed bellow tube	Open or replace tube
		Bellow tube blocked by water or dirt	Make free
		Bellow valve is not moving properly	Clean or replace