

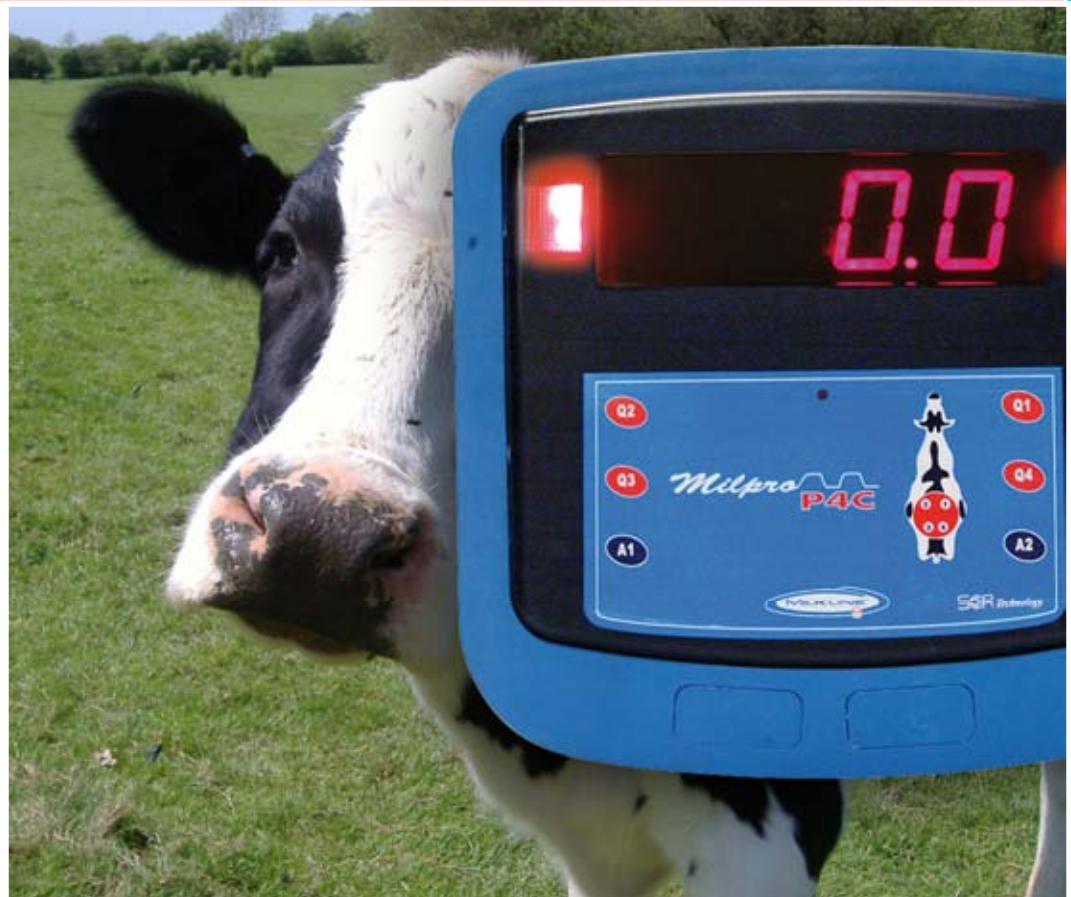

MilproP4C™

Advanced Milking Controller



**Installation &
Operation Manual**



MILKLINE srl
V277E – 31.03.2009



Table of contents

<i>Introduction</i>	6
<i>Overview</i>	6
<i>Main Features</i>	7
<i>The Milpro P4C™ Units</i>	8
<i>The System Main Modes</i>	12
Standby	12
Milking.....	12
Manual Milking	14
Rinsing	14
Rinsing Standby.....	15
Sleep Mode.....	15
Summary of System Modes.....	15
<i>Pushbutton Commands</i>	17
<i>Commands</i>	18
<i>Pushbutton Commands Table</i>	21
<i>System Installation</i>	24
<i>Wiring the Units</i>	30
<i>Maintenance</i>	35
<i>Appendices</i>	37
Appendix A - Parameters.....	37
Appendix B - Pulsation	45
Appendix C – “MC-Remote”, The Palm Software.....	48
Appendix D_1 – Calibration	54
Appendix D_2 – PULSAMETER 2 Calibration.....	58
Appendix E - Central Rinsing Switch.....	64
Appendix F1 – MILPRO P4C™	65



Appendix F2 – MILPRO P4C™ + PULSAMETER 2.....	66
Appendix G – MILPRO P4C™ WIRINGS DIAGRAMS.....	67
Appendix H – Spare parts.....	71



Introduction

Thank you for choosing Milkline's Milpro P4C™ Milking Controller system. This milking management system combines the most up-to-date and sophisticated features with ease of use, and we hope you'll enjoy using it. Please read this guide before starting the installation or operation.

Overview

The Milpro P4C™ is a microprocessor based, integrated control system designed for single milking-point management. It has many new and advanced features including milk yield and flow display, sophisticated pulsation programs with automatic stimulation, flow controlled pulsation, automatic cluster removal, kick-off and low milk alerts, remote-control programming, simple single pushbutton operation, and more.

It controls the milking process from the moment the operator mounts the cups and until the end of the milking process and the milking cluster removal.

The system consists of a small number of highly reliable components, and it is easy to install and operate. The Milpro P4C™ is modular and can be customized to (almost) any requirements. It enables the integration of additional identification and real-time network modules, to create a complete parlor's milking-management system.

The system can be used in parlors of any type including jar systems.

The system can be part of Milkline's MilConHM – a complete parlor management system, in this case the Milpro P4C™ serves a milk monitor device and a display for the MilConHM and is connecting on line to PC based system. Additional components such as cow ID readers and tags are also required. The system is designed for simple upgrade and enables gradual investment to suits the farmer needs.



Main Features

- Individual and milk-flow controlled pulsation for each milking point, for short (less than 20%) and efficient milking with minimal irritation to the cow
- A four digit LED display, monitoring milk yield, flow-rate, milking time and portraying milking status and alerts
- A milk flow sensor, based on IR Free Flow Technology, offering reliable and accurate milk-yield monitoring
- Pneumatic pulsation monitoring, including tubes failure and broken liners
- Automatic take-off - The system controls the vacuum operated shutoff valve and the cluster remover (take-off cylinder). The milk flow-rate's threshold determining detachment is adjustable.
- Kick-off and low milk alerts
- Simple operation using a single pneumatic pushbutton
- A highly flexible remote-control system with 50 different configurable parameters. The parameters can be configured using a Palm PDA with remote-control software
- An option for real-time network capability, enabling integration of *MilCon^{HM}* - a complete milking management system



The Milpro P4C™™ Units

The system is modular, consisting of several modules connected together.

Part no.	Name
-	MILPRO P4C™™ Controller
0393830M	MASTER EL. PULS. SERVO-PULSE 2 WAY
0540272	TCR COMPLETE PVC ML DV
0393760	FFS KIT DX FOR LOW LINE WITH VALVE
0393762	FFS KIT SX FOR LOW LINE WITH VALVE
03931983	ELECTRIC START BUTTON (N/C)
0750142	DF CONNECTION UNIT
0750145	DF CONNECTION UNIT FOR S/O



Units Description

MILPRO P4C™ – Controller

The MILPRO P4C™ is an integrated pulsation and control unit. Inside the unit there is an electronic PCB, consisting of a microprocessor and software that controls the pulsation and milking process.

The system has advanced software, which enables sophisticated pulsation schemes including teat-stimulation, milk-flow controlled pulsation, any rate and ratio, changing the take-off flow level and more. The system can be configured using a Palm PDA with special software.

(See “MC-Remote”, The Remote Control Software, Appendix C page 57). The MILPRO P4C™ has four digits LED display and flashing LED indicators for milk yield, alerts and other information.

MASTER EL. PULS. SERVO-PULSE 2 WAY

The MASTER EL. PULS. SERVO-PULSE 2 WAY is an electronic Master Servo Pulsator 24V.

TCR COMPLETE PVC ML DV

The TCR COMPLETE PVC ML DV is a pneumatic cylinder complete of 24V Double valve .

FFS KIT FOR MILPRO P4C™ DX FOR LOW LINE WITH VALVE

The FFS Kit includes the FFS30 Free Flow Milk sensor and the pneumatic vacuum valve. The FFS30 belongs to unique and patented Free-Flow milk-flow measuring devices. It measures the milk flow using Near Infrared (NIR) beams. The FFS30 is completely sealed and has no moving parts. The milk flows freely through the sensor inner tube.



Signals indicating flow- rate are sent to the control circuit in the Pulsator where they are processed to provide a wide range of indicators.

The FFS30 performs a self-test whenever it is connected to the power supply (also after power supply failure!).

Constant blinking of the FFS red light after connection to the power supply when there is no milk flow, indicates a failure of the self-test. In this case the sensor should be replaced. Note that if the system is configured for high line installation the FFS LED will blink with weak signal – This is normal.

ELECTRIC START BUTTON (N/C)

This simple and reliable pushbutton is connected to the DF Connection Unit. Simple pressing combinations enable complete control of the system.

For an overview and explanation of the available commands see 'Pushbutton Commands', page 16.

DF CONNECTION UNIT FOR MC/MILPRO P4C™/and S/O

The Connection Card allows for simple wiring of all the units.

The card is available also in a ready to install box including water tight glands and a power switch. See 'Wiring Diagrams' page 64/65



Operating the System

Note: The Parameters numbers (#) in the text refer to the menu numbers (first column) in the 'Parameter Table', appendix A, page 36

Power Up

The system mode after power-up is configurable (parameter #8.1.1) and also depends on the usage of the central rinsing command option. The most common options are:

Fixed Parlor:

- The power-up mode parameter will be set to standby (this is the default). However, if the rinsing command is ON, the system will power-up in rinsing mode and stay in that mode until the central command is turned off.

If the central rinsing command is not in use, the power-up mode will should be set to Rinsing, to ensure proper operation during the automatic rinsing cycle. In this case the operator should bring all the units to standby mode at the beginning the milking by double-press the pushbutton. At the end of the milking the power should be turned off and then turn on again to bring the units to Rinsing Mode.

RTS Systems:

- The Power-up mode should set to Milking.



The System Main Modes

Standby

In this mode the system is ready for the next cow or, in case of abnormal removal, ready for resuming milking on the current cow. The pulsation is off, the cluster is removed and the milk-valve closed. There are two standby modes:

- Normal standby mode – The LED indicators are on
- Abnormal standby mode (alert) – The LED indicators blink rapidly and the alert type is displayed

Milking

During normal automatic milking, the pulsation is on, the take-off cylinder is down and the shut off valve is open. The LED indication lights are off, and the LED Display shows the milk yield and other data according to the configuration (*For a complete summary of LED indications and display options see 'Display Summary', page 21*). This mode terminates when the milk flow-rate drops below the preset threshold (*configurable, see 'Summary of Pulsation Parameters' page 44*).

Stages During Milking:

- **Initial Time** - (parameter #1.1) a set time count starting at the beginning of the milking, designed to prevent early removal. During this time the system will not end the milking regardless of the milk flow. In normal conditions a cow will start giving milk during the Initial Time phase. If after this time the milk flow is still below the threshold (see below), the Secondary Time count will start and the milking will be terminated. If the milk yield was below the minimum (parameter #1.2) a "Low Milk" Alert will be displayed.



In case of reattaching the cluster to the same cow (indicated if attaching is done immediately after take-of, within the time interval defined in parameter #1.6) the initial time will be half of the normal parameter.

- **Normal Milking Termination** - When the milk flow rate goes below the preset threshold (50-1500 gr/min – parameter #1.4) a secondary timer (parameter #1.3) is triggered. At this stage the indication LEDs blink rapidly. At the end of this time, if the flow is still under the threshold and the procedure is not terminated by the operator, (see pushbutton commands), milking is automatically terminated. In the termination process the pulsation stops, the shut-off valve closes and the take-off cylinder is activated. The process comprises of 6 stages. The duration and output of each stage can be controlled individually, enabling for very flexible termination including “liner collapse”, suction of last milk and many other possibilities (see Take-off parameters).

- **Abnormal Milking Termination** (LEDS indication blinks rapidly).

An abnormal termination is defined as one of the following cases:

- a. The total yield at the end of the milking is below the minimum (parameter #1.2). In this case the termination procedure will be carried out as usual.
- b. The milk flow drops sharply (sensitivity parameter #1.8) to zero after a minimum yield, (parameter #1.5), which indicates that the milking cluster has fallen or slipped. In this case the shutoff valve is closed immediately and after a delay (parameter #1.9) the cluster will be lifted.



- **Stimulation** - This is a special phase during the milking mode.

In this phase, the Pulsator is running in high frequency (300 PPM - configurable). Because of this high frequency, the liners don't have time to collapse on the teats. This results in vibrations that massage the teats and stimulate the milk letdown. The stimulation can be started and stopped manually (*see pushbutton commands, 'Start stimulation', page 16*), or automatically - if the milk flow did not reach the required minimum within the predefined time. The stimulation will last up to a predefined interval length, or until the milk starts flowing. The stimulation mode starts automatically by default.

See stimulation parameters in section 3 of the parameter table, page 39.

Manual Milking

This mode is used for milking problematic cows. In this mode, the indication LEDs blink in the pulsation rate, the pulsation works normally, the take off cylinder is down and the milk valve is open. In this mode the automatic removal is disabled and the mode is terminated only by a pushbutton command.

Automatic stimulation is disabled but manual stimulation is possible if enabled in normal mode.

Rinsing

The MILPRO P4C™ has a Rinsing (Cleaning) mode. In this mode the pulsation is active, the take-off cylinder is down and the vacuum (shut-off) valve is open. The system goes to this mode by using a central switch connecting to all units (*see 'Wiring Diagrams' on page 64*). This enables initiating rinsing for the entire parlor with a single command, saving the need of doing it for each milking point manually. A message 'CLnS' is displayed indicating that this mode is on. *See 'LED Numeric Display' on p. 21.*



There is option to choose that the system will power up in Rinsing Mode (parameter #8.1.1)

Rinsing Standby

When applying a double press when the system is in standby mode the system will go to “Rinsing Standby” mode. In this mode the take-off cylinders will go down and enables the operator to mount the cluster on the rinsing jeters. The vacuum valve and the pulsation will be closed to prevent unnecessary vacuum drop. The units will go to Rinsing mode only after applying the central Rinsing Command.

”Rinsing Standby” is indicated by a 'CLnS' message

Sleep Mode

This mode exists (from s/w ver. 2059) to simplify installation and keep the system connected to power at all times. If there is no flow in the FFS for 30 minutes, the system is going to Sleep Mode. In this mode the solenoids are all at rest and the power consumption is minimal.

Once the Central Rinsing Switch is set to Milking the system returns to 'Standby Mode' (or to 'Rinsing Standby Mode' depending on parameter #8.2.6). 'Sleep Mode' is indicated by a 'running snake' on the display.

Summary of System Modes



	Mode	Description	Led Indicators	Vacuum	Take off	Pulsation
0	Power Up	Initial Mode	Depend on configuration			
1	Standby	Ready for next cow	On	Off	Up (On)	Off
1.1	◦ Standby, immediately after milking termination.	Enables continuation of the present cow	On	Off	Up	Off.
1.2	◦ Abnormal milking termination	Goes back to standby	Blinking rapidly	Off	Up	Off
2	Milking	The milking mode consist of sub modes:	Off			
2.1	◦ Initial delay	At milking start	Off	On	Down	On
2.2	◦ Secondary delay	Before take-off	One LED blinking very rapidly	On	Down	On
2.3	◦ Milking with manual stimulation	Teat stimulation	Off	On	Down	Very Fast
2.4	◦ Milking with automatic stimulation	Teat stimulation	Off	On	Down	Very Fast
3	Rinsing	For Rinsing Cycle	Off	On	Down	On
3.1	◦ Rinsing Standby	Rinsing preparation	Off	Off	Down	Off
3.2	◦ Sleep*	Between shifts	Off	Off	Down	Off
M	Manual Milking	Auto. Take off and kick-off handling are disabled	Blinking In pulsation rate	On	Down	On

* available from s/w versions 2059 and up.



Pushbutton Commands

Overview

The Milpro P4C™ is controlled by a single electric pushbutton.

Most of the operations are initiated with a single hit of the pushbutton.

For some, less frequent operations, a combination of hits is required.

The principle is simple and our experience shows that operators master it very quickly.

Note: *If the central rinsing option is used and the central rinsing switch is in rinsing position, the pushbutton will not react.*

The Pushbutton operation types are:

- Press the pushbutton once
- Press the pushbutton twice
- Long, continuous pressing of the pushbutton, for at least 2 seconds

The effect of each operation depends on the current system mode in which it is being executed.



Commands

Start Milking

Operation: hitting the pushbutton once.

Result: The cluster remover is released; the shut-off valve is opened (supplying vacuum to the cluster), enabling mounting of the cups.

Effective: in Standby Mode.

Terminate Milking and Rest Alerts (return to Standby mode)

Operation: hitting the pushbutton twice.

Result: This command returns the system to standby mode from almost every mode the system is in at that moment. However -if the system is already in standby mode, hitting the pushbutton twice will initiate milking.

Effective: in all milking and modes and if alert exists.

Change to Manual Mode

Operation: one long continuous press on the pushbutton, for at least 2 seconds

Result: Neutralizes the automatic milking termination. Switching to manual can be done during milking or immediately after it starts. The cluster remover is released and the cups are down or mounted on the cow

Effective: When the system is in standby or automatic mode

Terminate Manual Mode

Operation: one long continuous press on the pushbutton, for at least 2 seconds.

Result: This command reverses the Manual Mode command, and returns the system manual mode to normal (automatic) milking mode.

Effective: When the system is in manual mode.



Start Stimulation

Operation: hitting the pushbutton once.

Result: Initiates manual stimulation for 30 second.

Effective: While In milking or manual modes.

Note: *This command is rarely used. It is applied when a cow does not give milk and the automatic stimulation is disabled or didn't affect the cow.*

Terminate Stimulation:

Operation: hitting the pushbutton once.

Result: stops the stimulation and brings the system back to regular milking mode

Effective: While in stimulation mode, either manually or automatically initiated.

Commands Summary:

The effect of each command depends on the current system mode in which it is being executed.

Warning!: *the definition of the commands type (the intervals) was carefully chosen based on our long experience. However, they can be changed by configuring the pushbutton parameters. Please note that any change can result in severe interference with the unit operation.*



The effect of the pushbutton commands in various system modes is:

Single Press:

- In standby mode - Start milking (automatic milking mode).
- In Milking or Manual Milking modes - Start stimulation
- In Stimulation - Stop stimulation

Double Press:

- In Standby mode – Go to Rinsing Standby mode
- In all other modes - Go to Standby mode

Long Press (2 seconds):

- In Standby mode - Start Manual milking mode
- In Milking (automatic) mode - Change to Manual (the ACR will be disabled)
- In Manual mode - Shift back to normal (automatic) milking

Very Long Press (> 3.5 seconds):

This option is not in use from software version 2059 and onward.

In older versions or if parameter 8.2.6 CONCARD is set to "Old":

- In Standby mode (After both regular and irregular termination)
 - Go to Rinsing mode
- In all other modes – No effect



Pushbutton Commands Table

Note: The left column “Status No.” represents the system mode in which the action is taken. All other columns represent the system mode that result from the action specified in the column’s title. The numbers refer to the Status No.

in the left column. M = Manual

Status No.	Mode	Single Press	Double Press	Long Press	Very Long Press*
1	Standby	2.1	3.1	M	N/A*
1.1	<input type="checkbox"/> Initial time after take-off	2	2.1	M	N/A
1.2	<input type="checkbox"/> Standby after abnormal termination (Kick-off, Low milk)	2.1	1	M	N/A
2	Milking sub-modes:	2.3	1	M	N/A
2.1	<input type="checkbox"/> Initial delay	2.3	1	M	N/A
2.2	<input type="checkbox"/> Secondary delay	2	1	M	N/A
2.3	<input type="checkbox"/> Stimulation	2	1	M	N/A
3	Rinsing	N/A	1*	N/A	N/A
3.1	<input type="checkbox"/> Rinsing Standby	N/A	N/A	N/A	N/A
3.2	<input type="checkbox"/> Sleep	N/A	N/A	N/A	N/A
M	Manual Milking	M1	1	2	N/A
M1	<input type="checkbox"/> Stimulation (in manual mode)	M	1	2	N/A

***Very Long Press is canceled in s/w ver 2059 and onward. In older versions or if parameter #8.2.6 is set to "Old" and the system is in Standby it will bring it to Rinsing Mode(3).**

Note: When the central rinsing switch is on, the pushbutton is disabled and can't be used to control the unit.



LED Numeric Display

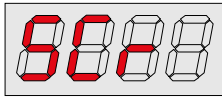

Appears at start up

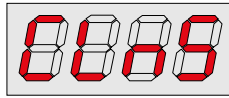

Rinsing Standby

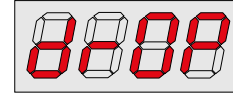

Drop Alert

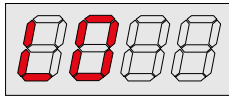

Low Milk Alert

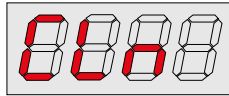

Rinsing

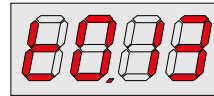

Milking Duration
In Min.Sec

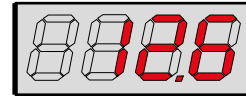

Milk Yield

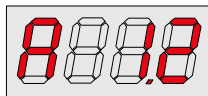

Avarage Flow

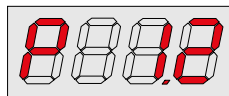

Peak Flow

After power-up, the system displays “MILKLINE” followed by the software version and then switches to the power-up mode (as defined by parameter #8.1.1) or to rinsing mode if central control is used and the switch is in Rinsing position.

The Data displayed during milking and in Standby mode can be one of the following 8 options (controlled by parameter #5.1)

1. Accumulated milk yield
2. Current flow rate - indicated by “F” on the left.
3. Milk yield and flow rate in alternation of 0.5 second
4. Same as 3 but at the end of the milking the average flow will be presented. Indicated by an “A” on the left
5. Same as 3 but at the end of the milking the peak flow will be presented. Indicated by a “P” on the left
6. Milking time in 0.00 (min. sec) structure indicated by “t” on the left



7. Accumulated milk yield and milking time in alternation of 0.5 second
8. Milking stages - for MILKLINE's technicians

Measurement Units - Kg or pound (and Kg/min or Pound/min for milk flow) can be selected using parameter #5.2.

Alerts

Alert messages take over the display and are displayed instead of the regular messages.

In an alert situation, the indication LEDS blink and the milk yield and the alert message alternate every 0.5 seconds.

- **Low Milk** - when the milk yield at the end of the milking is less than the specified minimum (parameter #1.2)
- **Kick-off** - When the cluster is dropped (sensitivity parameter #1.8)

Note: *If the system is connected to a management system ("MilCon^{HM}"), additional messages are available.*



System Installation

Overview

The MILPRO P4C™ is designed for simple and straightforward installation, making it suitable for upgrading existing parlors as well as new installations. The system contains advanced software, providing control over a large variety of parameters by using a remote control device. It enables optimal customization

to the parlor's configuration and the individual user's needs. Following the instructions detailed in this chapter will assure long-term functioning and full satisfaction.

Installing the system is quite simple. However, careful reading of the following instructions should save time and operational problems.

Note: *The installation should be done by an experienced technician of milking equipment.*

Preparation

Proper planning will assure smooth installation. The preparations should be as follows:

Examining the type of the intended parlor (existing or a new one) to determine the following:

- How the installation will be carried out
- The required accessories
- The required wiring
- The power supply



A meeting should be set up with the farm manager, to explain and discuss the various options, and decide on the best set of parameters. If the parlor is active the installation should be planned so as to minimize the interference with the normal milking routine.

The power supplies, cables, wiring braids, connectors and accessories should be prepared in advance. Special attention must be paid to the location of the Sensor and the Pulsator. See "Important Points to consider" in the next paragraph.



Picture 1 - General layout (Low Line)

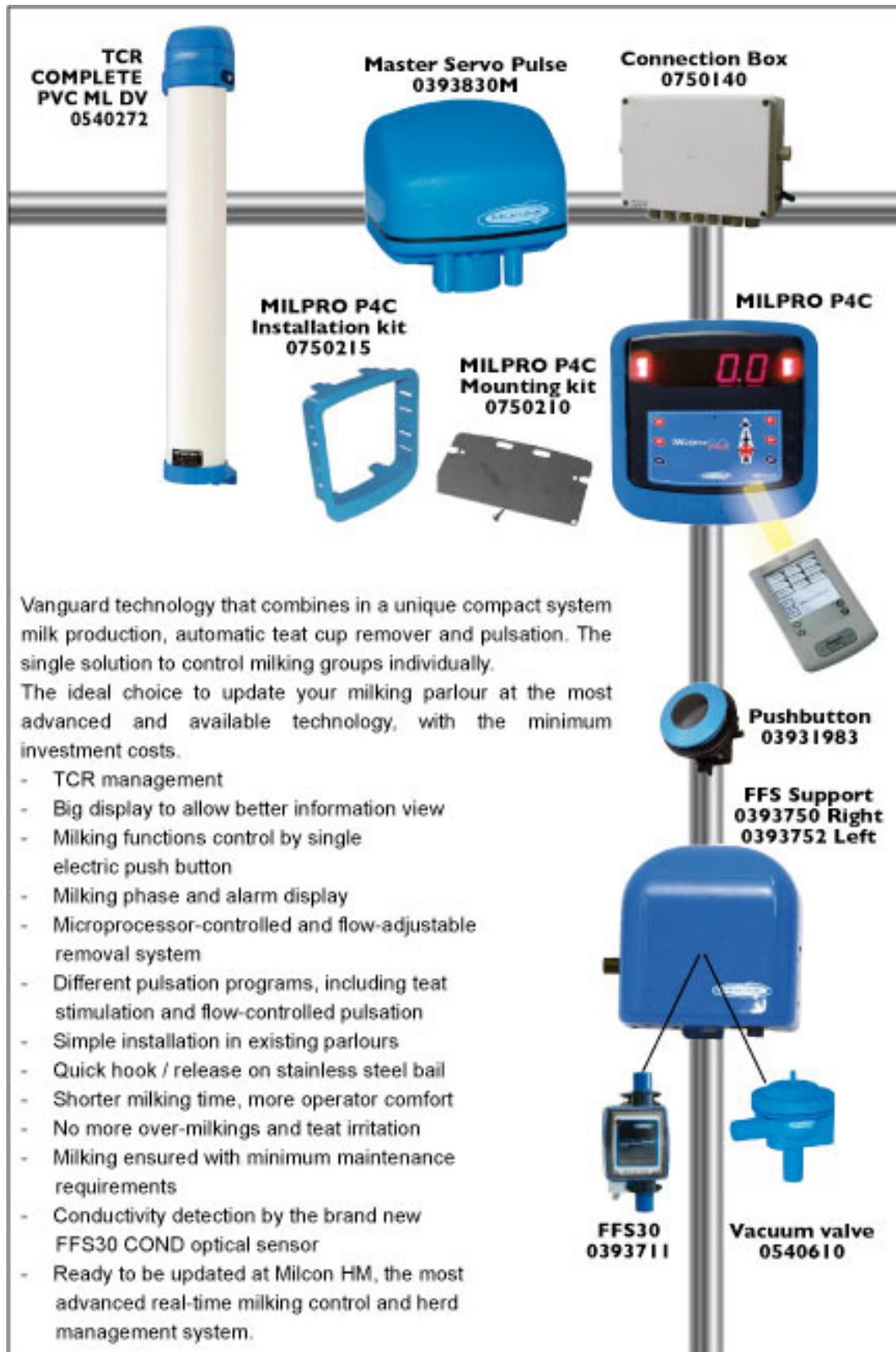



Units Installation

The following is an installation checklist. The steps listed don't necessarily have to be followed in the order listed.

MASTER EL. PULS. SERVO-PULSE 2 WAY installation

- Drill a 19 mm diameter hole in the pipe, and remove any swarf.
- Locate the Pulsator Multi Mount over the hole in the pipe with the flat face to the front
- Place the straps into the holes and pull them through until the buckles are seated in the mount.
- Bend the straps around the pipe and insert the strap end into the buckle.
- While holding the buckle firmly pull the strap through until it is tight.
- Vacuumise the plant and retighten the straps using pliers.
- Cut off excess strap.

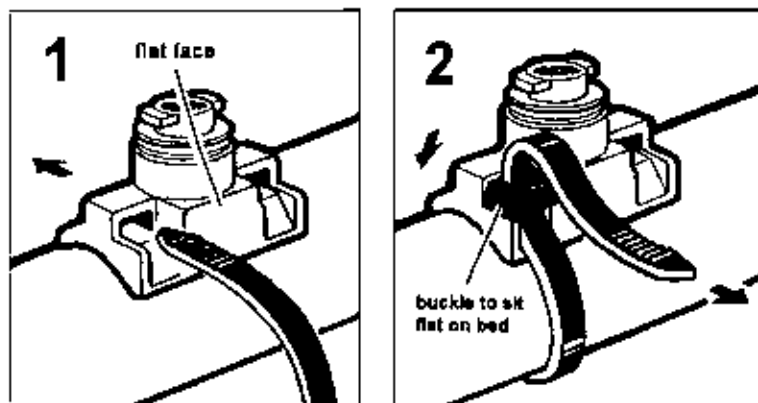

- Fit the connecting cable into socket 1 in the Master Pulsator and connect to the Connection Box (see wiring instructions pag. 64/65).



TCR COMPLETE PVC ML DV installation

The TCR complete PVC ML DV must be connected to the vacuum line and to the vacuum valve. The electric wirings must be connected in the Connection Box.





FFS Kit for low line with valve installation



FFS Kit is positioned on the milk pipeline and it is composed by FFS30 Infrared Milkflow Detector (connected into the Connection Box) and pneumatic valve (connected into the TCR Complete PVC ML DV).

Electric Start Button installation



The electric start button is useful to control the system and it should be installed in a place most accessible and convenient for the operator. It is connected into the Connection Box.



Wiring the Units

Important:

Before wiring the units please read the 'Wiring Instructions', page 30.

1. Wire the units according to the drawing. Every unit has differently marked cables. All the cables end up in a secured connecting point placed high in a conduit in the upper part of the parlor. The wires should be connected using the connections card.
2. Double-check that the wiring and the installation have been properly carried out, and connect the units to the power by starting the vacuum.

It is recommended to start by connecting only one milking point to the power and checking that the system functions well. After this first check has been successfully carried out you can connect the entire parlor

3. Choose the desired set of parameters and load all units (See "MC-Remote", *The Palm Software, Appendix D, page 57*)
4. Calibrate the units. (See "Calibration", *Appendix C, page 47*)



Wiring the Units

Important:

Before wiring the units please read the 'Wiring Instructions', page 30.

1. Wire the units according to the drawing. Every unit has differently marked cables. All the cables end up in a secured connecting point placed high in a conduit in the upper part of the parlor. The wires should be connected using the connections card.
2. Double-check that the wiring and the installation have been properly carried out, and connect the units to the power by starting the vacuum.

It is recommended to start by connecting only one milking point to the power and checking that the system functions well. After this first check has been successfully carried out you can connect the entire parlor

3. Choose the desired set of parameters and load all units (See "MC-Remote", *The Palm Software, Appendix D, page 57*)
4. Calibrate the units. (See "Calibration", *Appendix C, page 47*)



Wiring Instructions

We recommend using a special TRADO DUAL 24V power supply (0393579).

Trafo Dual 24V power suppli Diagram

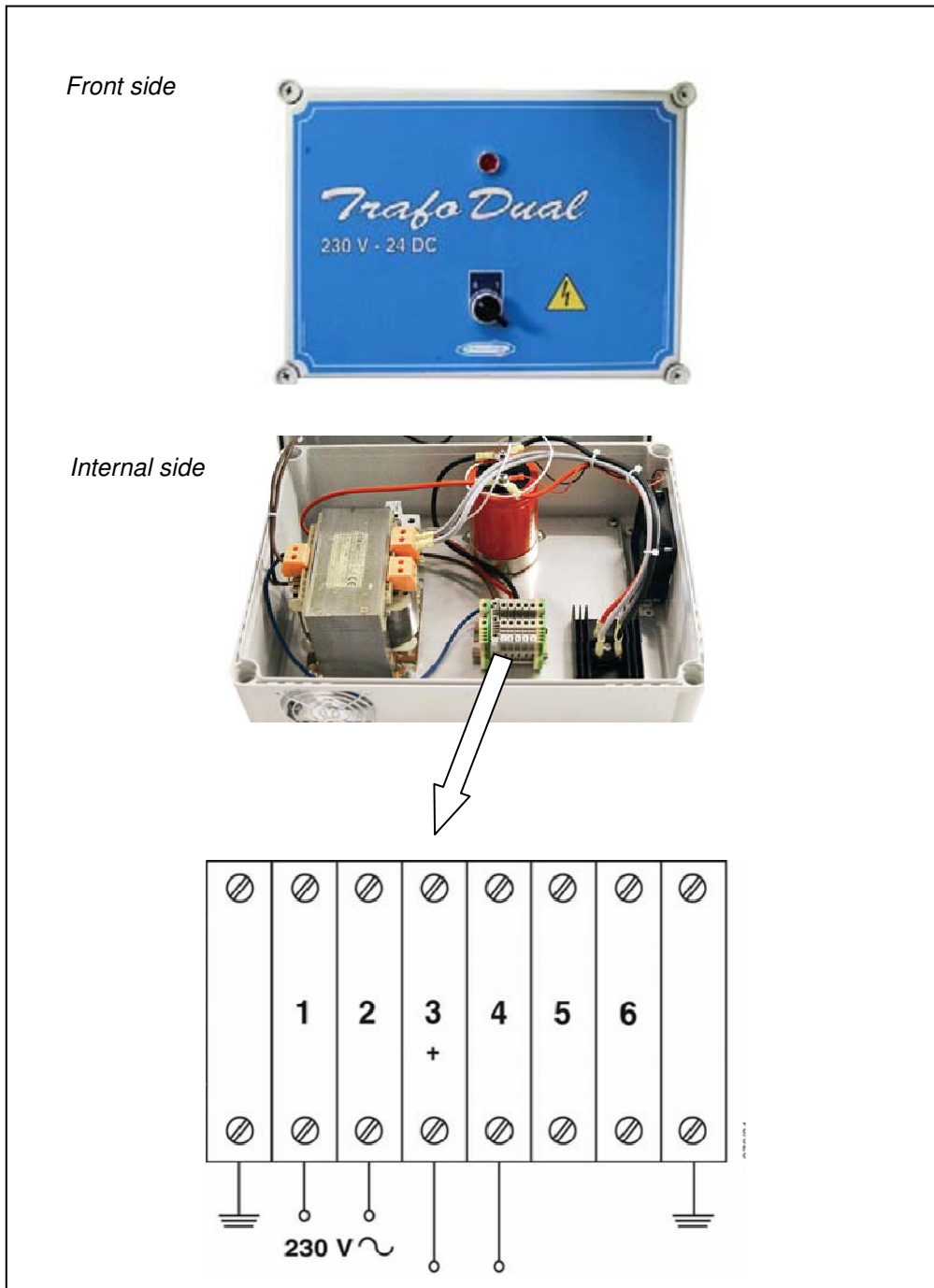



Connections Card (0750142 – 0750145)

The card enables to connect each cable to a dedicated port and considerably simplifies the wiring requirements. The card can be installed inside a proper box or in a conduit according to the specific installation. The card can be ordered in an IP 56 box with glands and ready to install. See drawing below. The card is suitable for *MilCon^{HM}* installation as well. (See page xx for connection wirings)

IP56 box within connection card

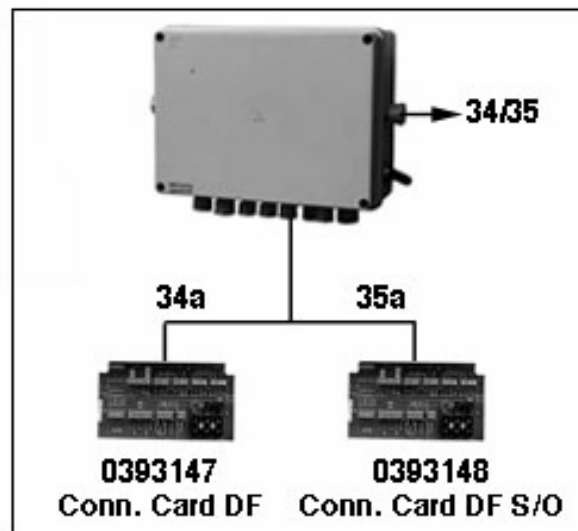



Power lines

For optimal performance we recommend keeping the system connected to the power supply at all times. The unit automatically goes in to "Sleep Mode" after Rinsing. (Starting from software version 2059)

Warning! *The Pulsators and Double Valves should not operated with out vacuum for long periods to avoid over hitting of the units.*

We recommend dividing the parlor into groups of 8-10 milking points with separate circuits and separate indication lights and circuit breakers for each group. Each power supply should be designed for 300VA. The common (-) of all the power supply lines should be connected together to enable the rinsing command.

Dividing the parlor in groups as described above helps to avoid big conductors (we recommend using stranded 2.5-4 mm² wires, (14-12 AWG) depending on the total length), as it is easier to maintain, and even in case of failure in one group, other groups will remain unaffected.

We also recommend using continuous conductors and special joints to "drop" the connection for each bail to avoid multiple hops.

In rotary parlors we recommend the installation of the power supplies on the platform.

Extension Cable for FFS

The extension cable connects the FFS to the Pulsator in low line installations. The cable should be a control cable with 4 stranded wires of 0.5 mm² (20 AWG).

We recommend the connections with the extension cables to be on the side of the pit in a suitable sealed box (common to all FFSs). The FFS can be ordered with longer cable if needed.



Rinsing Command

To bring all units to Rinsing Mode additional wire is connected to all units. Applying a (+) to this wire causes the units to turn to rinsing mode and applying (-) returns the parlor to Standby Mode. This option enables controlling the rinsing mode of the entire parlor.

***Note:** As it shown in the wiring diagram, the central rinsing switch should connect either(-) to the line or(+) for rinsing. The line should not be left "in the air".*

Network cable (for future connectivity to MilCon ^{HM}):

The network cable type should be **shielded** twisted-pair, stranded wires of 0.4 mm² (22 AWG) with characteristic impedance of 100 ohm and capacitance of 16 pF per foot. (Standard for RS-485). If the common (-) of all PS are not connected a third wire should be included.



Maintenance

Three Months Unit Maintenance

(In case of heavy dust this procedure may be repeated more frequently)

FFS30

The FFS30 doesn't require any maintenance.

MASTER EL. PULSATOR SERVO-PULSE 2 WAY

The internal air filter is designed as a secondary filter to ensure that only filtered air reaches the pulsation control solenoids.

This ensure maximum reliability under all conditions.

Check the filter material at least once a month or after every 200 hours of operation (more often in dusty conditions), and if it shows any build-up of dirt clean it wash it in warm soapy water. Squeeze it dry before refitting it. If the material shows any sign of degradation replace it with a new filter. Use only filters supplied by MILKLINE Milking Systems and its distributors.

The solenoids are factory sealed units and require no maintenance or servicing. If for any reason a solenoid does not operate correctly, replace it with a new unit. To remove a solenoid, unplug it from the circuit board, then release it from the retaining clips by lifting the end closest to the wires upwards and outwards.

To replace a solenoid, insert the ports into the middle plate, push the solenoid into the retaining clips, and plug the wires into the circuit board.

When replacing the lid ensure that the 1 mm diameter air admission hole in the end of the solenoid is unobstructed.

Replace the silicone diaphragm at intervals of 2000 hours of pulsator operation. Have the pulsator serviced by an approved service agent if pulsation graphs indicate leakage through the diaphragm.



TCR COMPLETE PVC ML DV

Monthly Maintenance

Open the bottom side of the cylinder and replace the cord if necessary.
Lubricate the internal part of the cylinder with silicon oil.



Appendices

Appendix A - Parameters

The MILPRO P4C™ has nearly 50 different configurable parameters. Configuring is done using a Palm™ PDA with special software.

The software enables to create, save, upload and retrieve either predefined complete parameters sets, or change specific parameters.

The parameters are divided into 9 groups, each handling different aspects of the MILPRO P4C™ functionality as follows:

Note: the name in capital letters in the brackets refers to the button in the MC-Remote software, see Appendix C, page 57, and the Parameters tables, appendix A, page 38

1. Milking [MILK] – Milking process control, various delays, flow threshold for removal, abnormal termination conditions control etc.
2. Pulsation [PULS] – Controlled or fixed pulsation, see appendix B, Pulsation, page 44
3. Stimulation [STIM] – teat stimulation control, frequency, duration, operation, etc.
4. Pushbutton Control [BUTT] Pushbutton commands definitions; usually there is no need to adjust these parameters
5. Display [DISP] – Changing the display mode and units
6. Take-Off Settings [TKOFF] – take-off process definitions; usually there is no need to adjust these parameters.



7. Non Milking Statuses [NMILK] – System output definitions for standby and rinsing modes; usually there is no need to adjust these parameters.
8. General [GNRL] – Power-up and setup parameters.
9. Special I/O Function [FUN_IO] – Special I/O wire-terminal functionality definitions. These parameters should be changed by the system installer according to the wiring.



Parameters table 1

Menu no.	No.	Name	Description	Units	Values Range	Default	Notes
			Main				
I		Parameter	Change specific parameter				
II		Sets	Work on a complete set of parameters				
II.I		READ_F	Retrieve parameter set from the MILPRO P4C™				
II.II		READ_P	Retrieve parameter set from a Palm file				
<i>The parameters menus are common for setting a specific parameter or working on a complete set</i>							
1			Milking				
1.1	1	MDURS	Initial interval	Sec	50-300	100	See page 7
1.2	2	MGRAM	Minimum yield (for low milk alert)	Gram	500 – 10,000	3,500	
1.3	3	FMDRS	Final interval	Sec	5 – 30	12	
1.4	4	FHTCS	Flow threshold for removal	Gram	50 – 1500	350	
1.5	13	MDGRM	Min. yield for drop alert	Gram	0 – 30,000	500	
1.6	31	OFDSC	Interval before reset of last cow data	Sec	0 – 180	5	
1.7	37	VACDY	Delay of opening shut off valve	Sec	0-5	1	
1.8	42	SNDRP	Sensitivity of drop (kick-off) detection		-Quick -Normal -Slow -Very Slow	Normal	
1.9	41	TOVHAN	Delay for take-off in drop (kick-off) event	Sec	0-60, 990,991	15	990 - take off disabled 991- in Lo milk alert the cluster stays up



Menu no.	No.	Name	Description	Units	Values Range	Default	Notes
2			Pulsation				
2.1			<u>Flow Controlled</u>				
2.1.1	19	LF	Low flow	Gr./Min	0-3,000	1,200	
2.1.2	20	HF	High flow	Gr./Min	2,000-10,000	7,500	
2.1.3	16	LFAB	Milking phase at low flow	10 X msec	10-100	60	
2.1.4	15	LFCD	Rest Phase at low flow	10 X msec	10-100	40	
2.1.5	18	HFAB	Milking phase at high flow	10 X msec	10-150	107	
2.1.6	17	HFCD	Rest Phase at high flow	10 X msec	10-100	40	
2.2			<u>Fixed pulsation</u>				
2.2.1	16	AB	Milking Phase	10 X msec	10-100	60	
2.2.2	15	CD	Rest Phase	10 X msec	10-100	40	
2.2.3	36	PPLB	Reduced Milking for front quarters	%	0-20	0	
2.3		PULSSTYLE	Pulsation Style		1: 2x2 2: 4x0	2x2	Software Ver 1029 and above
3			Stimulation				
3.1	22	MSGPB	Interval of phase A+B in stimulation	10 X msec	10-15	10	
3.2	21	MSGPD	Interval of phase C+D in stimulation	10 X msec	10-15	10	
3.3	23	MSGMF	Flow limit for auto. Stimulation	Gr./Min	60-1800	1000	
3.4	24	MSGMD	Max. stimulation interval	Sec	10-100	30	
3.5	38	AUTEN	Delay for auto. Stimulation (depends on flow limit)	Sec	0-300	30	
3.6	25	ENMSG	Stimulation status		1.Disabled 2.Manual 3.Auto 4.Auto+Man	Auto	
4			Pushbutton				



Menu no.	No.	Name	Description	Units	Values Range	Default	Notes
			control				
4.1	26	MINSHORT	Lower limit for short press	msec	20-600	40	
4.2	27	MAXSHORT	Upper limit for short press	msec	620-2,000	1,200	
4.3	28	MAXLONG	Max interval for long press	msec	2,010-4,000	3,500	
4.4	29	MINOF	Min. interval between two presses for double press	msec	20-600	40	
4.5	30	MAXOF	Max. interval between two presses for double press	msec	620-2,000	700	
5			Display				
5.1	34	DDMODE	Display mode		See table 2 on page 58	Yield	
5.2	35	DISPUNIT	Measuring units		Kg, Pounds	Kg	
6	5-10		Take Off Setting	See table 3 on page 59			
7			Non Milking Statuses				
7.1	11	NMILKSET	System status in standby mode				
7.2	12	CLENSET	System status in Rinsing mode				
8			General				
8.1			<u>Power up</u>				
8.1.1	39	PWR_UP	System Status at power up		1: Manual 2: Rinsing 3: Standby 4: Milking*	Standby	*software Ver 1029 and above
8.1.2	40	VV_DLY	Delay for opening the shutoff valve at power up	Sec	0-300	0	Needed if vacuum reserve is low
8.2			<u>System setup</u>				
8.2.1	43	BIAS	Set constant correction to sensor input		600-1500	1000	See App. C page 63



Menu no.	No.	Name	Description	Units	Values Range	Default	Notes
8.2.2	48	SENSOR	Define type of sensor installation		1.High Line 2.Low Line	New Protocol Lo line installation	** See Note below
8.2.3	49	SHOFFT	Define the Shot-off valve type		1.Diaphrag m 2.Clamp	Clamp	Ver 1026 and above
8.2.4	50	ACRMODE	ACR mode		1: Take-Off Cylinder 2:Pulsation Arrest	Take-Off Cylinder	Ver 1029 and above
8.2.5	59	ADDRESS	Node Address				<i>MilCon^{HM}</i> & special applications
8.2.6	60	SLEEP	Sleep Mode Style		1: Old 2: Wake up in 'Standby Mode' 3: Wake up in 'Rinsing Standby Mode'	Wake up in 'Standby Mode'	See page 73 for more info
8.2.7	65	REMROT	Functionality of rotary remote control		1: enable reset while milking 2: Disable reset while milking	1: enable reset while milking	Rotary- fixed remote control
8.3			<u>MC201 (MilCon^{HM})</u>				
8.3.1	61	IDENT	Type of ID				<i>MilCon^{HM}</i>
8.3.2	62	PARLOR	Parlor Type				<i>MilCon^{HM}</i>
9			Special I/O				
9.1	46	IN/Rinse Active only if param 8.2.6 is in Old	Old Rinsing Standby configuration		1: Single Press 2:Conditional	2: Conditional	in Ver 2059 And above In old mode
9.2	47	OUTPUT	Currently not in use				
9.3	63	DRPDLY	A special function for lowering the cluster during milking for back-flush	Sec	5-120	10	Use with special device for rinsing between gangs



Warning! The Parameters in tables 2 and 3 have complicated effects and should be changed only by an expert with full understanding of the system.

Parameters Table 2

Display Modes (5.1 in Table 1)

	Display Mode	Default
1	Yield Only	X
2	Flow Only	
3	Yield & Flow	
4	Yield & Flow / Average Flow	
5	Yield & Flow / Peak Flow	
6	Milking Time	
7	Yield & Milking Time	
8	Milking Stages - Service Only	

**** Note:** If the system is configured for high line installation the (parameter 8.2.2) the FFS LED will blink constantly with faint signal after the power up self test.

The Take-off process consists of 6 consecutive stages (0 to 5). The duration and the state of each output (valves and signal lights) can be set separately for each stage. As a result the process is highly flexible and can be adjusted to any requirement. The default set enables smooth take-off with last milk sweeping. In most cases these values should not be changed. In a similar way the outputs can be set for Standby and Rinsing modes for special cases.



Parameters Table 3

Menu 6: Take-off Stages									
Stage	No.	L2	L1	TOV	VV	Pv2	Pv1	Duration 100X msec	Range
0	5	On	On	Off	Off	On	On	30	0-128
1	6	On	On	On	Off	On	On	50	0-128
2	7	On	On	On	On	Off	Off	10	0-128
3	8	On	On	On	Off	Off	Off	10	0-128
4	9	On	On	On	Off	Off	Off	0	0-128
5	10	On	On	On	Off	Off	Off	0	0-128
Menu 7: Non milking modes									
7.1- Standby	12	Off	Off	On	Off	Off	Off		
7.2 - Rinsing	11	Off	Off	Off	On	Puls	Puls		

Key:

L1, L2 – Signal LEDs ; TOV – Take-Off Valve ; VV – Vacuum (Shut-Off) Valve ;
PV1, PV2 – Pulsation Valves;



Appendix B - Pulsation

The pulsation parameters define the milking phase (A+B) and the rest phase (C+D). The phase duration values are given in 10th of millisecond. In the following table we show few common settings that will help you understand the translation to rate and ratio:

No.	Rate PPM	Ratio %	Milking phase A+B (10 th msec.)	Rest phase C+D (10 th msec.)
	60	60:40	60	40
	55	60:40	65	44
	60	65:35	65	35
	60	70:30	70	30

The MILPRO P4C™ has two pulsation modes:

- Flow-controlled pulsation
- Fixed pulsation.

Flow-Controlled Pulsation (default)

In this pulsation method, the pulses are changing dynamically during the milking, reacting to the milk flow. As the flow increases the pulsation's milking phase (A+B) becomes longer, while the rest phase (C+D) remains constant. As a result, the pulsation rate slows down. This performance is achieved because the FFS is monitoring the flow online and in real time, unlike other systems where the flow monitoring is very limited.

The idea behind the controlled pulsation is that high production cows can benefit from milking in longer strokes since the duct system and the teat cisterns in the udder are larger. The benefits are faster milking (up to 20% reduction in milking time), less teat irritation, and less liners



wearing. The method is also very safe because if, for whatever reason, the cow is uncomfortable with longer strokes the flow rate will decrease and the pulsation will immediately change back to the initial values.

The controlled pulsation 6 parameters are:

1. Low flow rate - the flow level in which the pulsation starts changing (Parameter #2.1.1)
2. Milking phase (A+B) in low flow rate (Parameter #2.1.3)
3. Rest phase (C+D) in low flow rate (Parameter #2.1.4)
4. High flow rate – the flow level in which the pulsation stops changing (Parameter # 2.1.2)
5. Milking phase (A+B) in high flow rate (Parameter #2.1.5)
6. Rest phase (C+D) in high flow rate (Parameter #2.1.6)

Parameters 1 & 2 above determine the initial pulsation (in milliseconds – see the table below). The pulsation stays constant as long as the flow is below the low flow-rate (1). Between the low flow level and the high flow level (4) (the dynamic area) the pulsation will change in accordance with the flow.

When the milk flow is above the high flow-level, the pulsation will be constant according to parameters 5 & 6.

We recommend using default setting. These settings are the result of 10 years of field experience in Israel and Europe. After gaining some experience with the system, the parameters can be changed based on your own field experience.

Customers are most welcome to send us comments and feedback on the system performance.



Fixed Pulsation

If you choose to use fixed pulsation you only need to change two parameters - the milking phase (#2.2.1) and the rest phase (#2.2.2)

Note: *Parameters 2.2.1 and 2.2.2 control the initial pulsation if controlled pulsation is used, and also the fixed pulsation and the pulsation during rinsing.*



Appendix C – “MC-Remote”, The Palm Software

Overview

The MILPRO P4C™ is configured by an infrared remote control similar to that of a TV set. By installing the MC-Remote software on a Palm PDA it is easy to control all the MILPRO P4C™ features. This chapter deals with installing and using the palm software.

For details and description of the different configurable parameters see the parameters table on page 38

Specifications

Device*: Palm -Vx, m130,m505, m515, Zire (m150), TUNGSTEN E/T,
Sony - CLIE SJ10, CLIE SJ22

Software version*: PALM OS 3.5, 4.1, 5.2.1

*Different Devices and OS require different files -
see README.TXT in the MC_Remote files set.

Modules

1. **Remote.prc** - IR controller.
2. **MC_Remote.prc** - The configuration software.



Installing and Registering the Software

The modules are installed from a PC like any other Palm software, using the “Palm Desktop”.

1. Make sure that the Palm Desktop Software is properly installed on your PC and connect the PDA to the PC.
2. Double click on the files **Remote.prc ORLibxxx.prc** (xxx represents the file version according to the device and OS in use) and **MC_Remote-vyyyy.prc** (yyyy represent the file version) supplied by MILKLINE.
3. The Palm’s “Install Tool” Dialog box will appear after the first click and both files will be added to the list of files in the box. Press “Done” and then “OK”
4. Synchronize your Palm by pressing the “HotSync” button on the docking station. The Icons of both modules should appear on your Palm’s main menu.
5. Send your user name to the palm (click the HotSync icon - the name is written in the right upper corner of the screen)
6. Send the user name to sales@milklime.com and we will send you a registration code for the Remote.prc module
7. After you received the code, click the ‘Remote Icon’, click on the ‘OmniRemote Pro’ label at the upper right corner, choose ‘Option’ then ‘Registration’ and insert the code

As a bonus you can train the palm to act as a TV remote control – see the Remote Module.



Using the Software

The MC-Remote is a simple, menu-based program that enables you to do the following:

- Retrieve and save the parameters-set from the MILPRO P4C™ on the Palm
- Edit a parameter set
- Load a parameter set to the MILPRO P4C™
- Retrieve, change, and load any single parameter

Like any other IR device, in order to communicate the Palm topside should point to the direction of the MILPRO P4C™ front panel.

A successful transmitting will be indicated by a bleep in the palm and by a short "Done" message on the MILPRO P4C™ display.

After clicking on the MC-Remote Icon, a two items menu will appear:

Picture 1 - Top Menu



The PARAMS button enables you to browse through all the parameters and retrieve, change, and load any of them.

The Parameters are divided into 9 submenus, each handling a different functionality.



Picture 2 – Parameters Submenus (shown in “Single Param” mode)



There are two types of parameters:

1. **Open parameters** - These are parameters with a value that can be freely entered. They can be handled individually or as part of a parameters set.
 - a. When handled individually the value can either be written (or keyed) in, or retrieved from the MILPRO P4C™. The updated value can then be uploaded to the MILPRO P4C™ using the ‘transmit’ button.
 - b. When handled as part of a parameters set the parameter value can be freely entered and saved but only the set can be retrieved and uploaded to the MILPRO P4C™.

2. **Closed-set parameters** - These are parameters with a predefined set of values.
 - a. In single parameter mode, once you select the parameter the software will automatically try to read the current value from the pulsator – so make sure you hold the Palm facing the unit you want to



update. After selecting the desired value, pressing the 'Done' button will automatically load the setting to the unit.

- b. In Sets mode the selection can be changed and saved by pressing the 'Done' button. Use the 'Esc' button to leave the setting unchanged.

Warning! While the MILPRO P4C™ is very flexible and can be adapted to various conditions, some of the parameters are less likely to be changed and some can disrupt the proper system operation if carelessly changed. For those parameters an additional password is required.

To work on a whole set choose SETS.

After choosing SETS you can either choose any set that was previously saved or retrieve a complete set from the MILPRO P4C™. After retrieving a set you can change it and reload it to the MILPRO P4C™.

The menus for changing a single parameter or working on a set are similar. A message at the lower half of the screen will indicate the mode of operation.

Help

Clicking on the HELP button at each submenu will present a list of descriptions of all the parameters belonging to that submenu.



Common Tasks

Configuring the MILPRO P4C™ in a new installation

After deciding on the desired configuration, go to SETS, choose READ_F, Pick the set which is nearest to your needs, save it under a new name using SAVE_AS, change all the parameters that need to be changed, save it using SAVE, and then load it to the first MILPRO P4C™. Check that the milking point is functioning well, make adjustments and then load the same set to all the other units.

Changing a single parameter

Go to PARAMS, browse in the menus for the required parameter. If the parameter has a close set of options to choose from the software will automatically try to retrieve the current setting. If the value is numeric then the current value can be retrieved from the MILPRO P4C™ by using the READ button in the parameter screen. After changing the parameter, load it back to the MILPRO P4C™ using the TRANSMIT button.

To make sure that the configuration is identical in all units in case that more than one parameter was changed, it is recommended to retrieve the updated set from the first unit, save it under a new and meaningful name (our advise is to include the date) and then load the complete set to the rest of the units.



Appendix D_1 – Calibration

In order to achieve optimal accuracy, the MILPRO P4C™ (like any other measuring device) requires initial calibration. The calibration is needed to adjust the MILPRO P4C™ for the special conditions of a specific parlor.

The calibration does not influence the basic accuracy of the MILPRO P4C™ but it can correct a “shift” (called bias) in the measurements that can occur due to specific conditions.

Since the MILPRO P4C™ is very stable, calibration is needed only once after installation and from that point on the MILPRO P4C™ will be accurate as long as the parlor remains the same and no changes were made on the installation or milking equipment. We will demonstrate two ways to perform the calibration, by using the total milk in the tank and individual calibration.

Prior to calibration check the parlor for normal and standard milking conditions:

- Normal vacuum levels (44 ± 2 kPa for low line and 48 ± 2 kPa for High line)
- All clusters in good shape (bleeder, liners, tubes etc...)

Calibration Using the Milk Tank (Vat)

This method is relatively simple and does not require any equipment. In most cases this option is sufficient for achieving good results.

Requirements:

- Accurate scale in the milk tank.
- Palm with MC-remote software



Procedure:

1. Write down the amount of milk in the tank.
2. Start the milking.
3. Write down the milk yield of each cow as it appears on the MILPRO P4C™ display.
4. At the end of the milking calculate the average bias:
 - a. Write down the exact volume of milk in the tank.
 - b. Calculate the net amount of milk for this milking by subtract the volume in the tank at the beginning of the milking, add milk that was taken to feed calves etc...
 - c. Convert the total volume to weight (kg) by multiply the volume by 1.032 (denote -Yt).
 - d. Sum the yield of all the cows as they appear on the MILPRO P4C™ (denote -Ym)
 - e. Calculate the average bias for the parlor:

$$\text{Bias} = Yt / Ym * 1000$$

5. Adjust the bias of all units using the Palm.
6. Save the new bias in the parameters set for this parlor.

Example:

If the amount of milk in the tank is 540.2 liter and 20 liters of milk was taken to feed calves, and the calculated sum of all the yields of all the cows is 590.6 kg then the bias is:

$$Ym = 590.6 \text{ kg}$$

$$Yt = (540.2+20) \text{ liter} * 1.032 \text{ kg/liter} = 578.12 \text{ kg}$$

$$\text{Bias} = Yt / Ym * 1000 = 578.12 / 590.6 * 1000 = 979 \text{ (rounded)}$$

This bias should be updated in the Palm on the parameter file for that parlor and transmitted to all units in the parlor.



Individual Calibration

In this method the calibration is done individually for each milking point, which is more accurate but requires more work.

Required accessories:

- One or more 30 liter vacuum buckets for collecting the milk.
- Accurate (± 10 gr) scale to weight the milk bucket/s
- Palm with Mc-Remote software

In this method every unit is calibrated individually.

Procedure:

1. choose a milking point, connect the collecting bucket and milk 6-8 different cows (if the results are similar i.e. the tendency of the bias is the same then 4 cows maybe enough) , make sure that the milking is normal and finished in a normal way. Write down the yield of each cow as it appears on the display at the end of the milking together with the true yield from the scale (remember to reset the scale with the bucket !!!)
2. Calculate the Bias:
 - a. Sum all of the yields from the MILPRO P4C™ and disregards yields of abnormal cows (colostrums, Mastitis low yield, manual milking etc..) (Ym).
 - b. Sum all the yields from the scale for the same cows. (Yt)
 - c. Calculate the bias same way as explained above (See 1.4).
Bias = $Yt / Ym * 1000$
3. Adjust the unit bias by using the Palm.
4. Repeat steps 1 to 3 for all milking points in the parlor.



Example (Individual Calibration):

Milking point No. 1

No.	Cow	MILPRO P4C™ (Ym)	Scale (Yt)	Remark
1	101	11.2	11.6	
2	80	9.4	8.7	
3	69	8.3	8.3	
4	125	13.2	14.1	
5	142	12.0	11.8	
6	93	3.2	3.1	Mastitis
7	44	10.6	11.0	
Total*		Ym 64,70	Yt = 65,5	

* Disregard result No. 6 since it is a sick cow.

Bias = 65.5 / 64.7 * 1000 = 1012 (Rounded)



Appendix D_2 – PULSAMETER 2 Calibration

The system is pre-set with factory parameters to work immediately but after the installation at the milking positions, an adjustment to each milking point has to be carried out by a fine calibration procedure.

At the Start Up of the system

When the milking system is put into operation the first time or when a milkmeter of the system is exchanged, the calibration value of '100' is set as default. A fine calibration is to be done four weeks after the first start up. The fine calibration procedure have to be carried out according to the following points of these instructions. At the first calibration procedure as well as at routine checks, always qualified personnel are to be consulted, in order to remedy distinguishable deficiencies.

Required equipment for the Calibration Procedure.

The followings tolls have to be selected in order to perform the calibration procedure:

- a suitable milk can,
- a scale with 10 g of resolution,
- a standardized intake tube with concave intake nozzle (3 kg/min) and air nozzle (8-10 l/min),
- a bucket of at least 10 kg capacity,
- a thermometer.



The Set Up for the Calibration Procedure

The followings tasks have to be made in order to correctly set up the calibration procedure:

- the bucket is to be filled with water with a temperature of ca. 30 °C and is to be put on the platform of the cow,
- the long milk tube of the milking unit is to be taken off from the inlet connections and the standardized intake tube of the test unit is to be attached on these connections,
- before every measuring the tipping scale is to be emptied by operating the two air inlet plates on the top of the milkmeter,
- the end of the tube with intake nozzle is to be dipped down to the bottom of the bucket. The concave end of the intake nozzle avoids that the nozzle adheres at the bottom of the bucket,
- when the system start the milking, the water is to be sucked off out of the bucket. The suction nozzle must not suck air and must not be blocked,
- stop the milking when the bucket contains a quantity of $10 \pm 0,2$ kg.

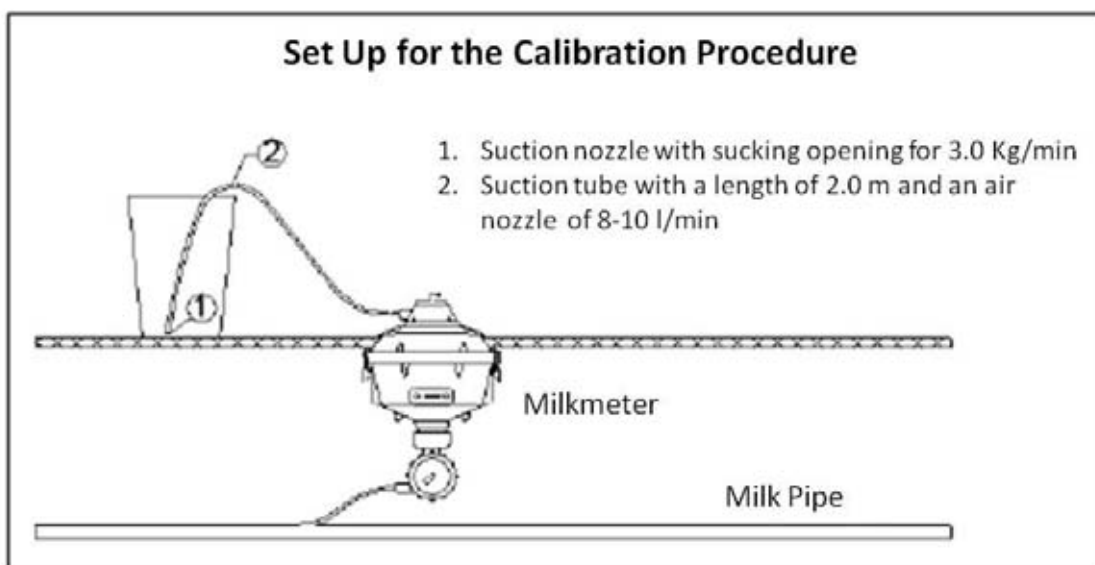



The Calibration Procedure

The followings tasks have to be made before perform the calibration procedure:

- at least two measurings have to be carried out according to the section 4.3 of this document,
- if the bucket contains 10.0 Kg. and the displayed values are $10.0 \pm 0,2$ kg, the previous calibration parameter or the default value in case of a new system, can remains unchanged and no further measurement is necessary,
- If the displayed values exceed these limits, a calibration procedure to correct these errors is necessary.

Examples:

1. First measuring: Display = 9,9 kg
2. Second Measuring: Display = 10,0 kg

➤ *Calibration Parameter: o.k.*

Or

3. First measuring: Display = 9,7 kg
4. Second Measuring: Display = 9,8 kg

➤ *Calibration Parameter: the calibration procedure have to be performed.*

The followings tasks have to be made in order to perform the calibration procedure:

- start the milking according to the section 4.3 of this document,
- stop the milking when the bucket contains a quantity around 10 kg,



- record the value on the display. The value on the display can only be taken after the stop of the milking. That is because the milkmeter automatically adds 51 grams (the half of the tipping device) to the recorded quantity of milk when the pushbutton is pushed twice and the LED indication lights remain on.
- Record the weight of the water inside the bucket measured by the balance,
- calculate the Calibrated Volume by the following formula:
 - $\text{Calibrated Volume} = (\text{balance} / \text{milkmeter}) \times 100$
- Repeat the previous tasks at least three times to collect three correct measurings. A measuring is considered to be correct if its value compared to the average value of the other measurings is less than 2%.
- Calculate the Calibration Parameter as the average value of the tree correct measurings collected

Example 1:

<i>Display</i>	<i>Balance</i>	<i>Difference (in litres)</i>	<i>Corrected Volume</i>
10.5	10.83	-0.33	103.14
10.9	11.24	-0.34	103.12
10.8	11.11	-0.31	102.87

- On the basis of these results the average value is determined as following:
- $(103.14 + 103.12 + 102.87)/3 = 103.04$
- and the Calibration Parameter can be set to 103.



Example 2:

<i>Display</i>	<i>Balance</i>	<i>Difference (in litres)</i>	<i>Corrected Volume</i>
10.8	9.92	0.88	91.85
10.8	10.51	0.29	97.31
10.7	10.39	0.31	97.10

- In this example the average value of the first three measurements is 95.42. The measurements may deviate 2% from this average (i.e. from 93.51 to 97.33) so that the first measuring is not correct and a fourth measuring is necessary in order to figure out the Calibration Parameter.

Example 2b:

<i>Display</i>	<i>Balance</i>	<i>Difference (in litres)</i>	<i>Corrected Volume</i>
10.8	9.92	0.88	91.85
10.8	10.51	0.29	97.31
10.7	10.39	0.31	97.10
10.5	10.10	0.40	96.19

- On the basis of these four results the average value is determined as following: $(91.85 + 97.31 + 97.10 + 96.19)/4 = 95.61$
- and the Calibration Parameter can be set to 96.
- Please note that If an extreme measuring is found during the determination of the volume (e.g. a volume of 101 in the above mentioned example), this measuring must not be taken into account when calculating the average in order to prevented that one measuring has too much influence on the average value.

To complete the calibration procedure, the Calibration Parameter have to be stored in the Milpro P4C™ microcomputer. This operation can be done using a Palm™ PDA with a special software. The software enables to create, save,



upload and retrieve either predefined complete parameters sets, or change specific parameters.

In details, the storing of the Calibration Parameter is done by the following steps:

- Start the software application on the PDA,
- select “Sets”,
- read the setting data from the Milpro P4C™ by its IR port selecting the button “Read_P”,
- in the “Param Menu”, select: “GNRL”,
- insert the authorization password: SCR,
- in the “General Menu”, select “MEL”,
- insert the authorization password: milkline,
- in the “Mel Menu”, select “H_PAS”,
- the default or previous value is displayed. Update it with the Calibration Parameter evaluated and select “Ok”,
- select “Esc” until came back to the “Param Menu”,
- select “Save” to store in the PDA the last set of parameters,
- select “Trans” to transfer to the Milpro P4C™ the correct set of parameter by its IR port,
- select “Esc” until quit the application.

Afterwards, a new test for checking the updated system have to be carried out following the tasks explained in the start of this section . If these measurements are within the range of tolerance, the calibration procedure is completed.



Appendix E - Central Rinsing Switch

The central rinsing switch can be operated manually or automatically by the rinsing unit. When the switch is in Rinsing position on the units receive +24V in the I/O function input which bring them immediately to Rinsing Mode. The units will display “CLn”

In order to enable preparation of the parlor for rinsing as quickly as possible we added a special mode “Rinsing Standby” in which the clusters are lowered but the vacuum is closed and the pulsation is arrested in order to keep the vacuum level stable for the cows which are still in milking. This enables to prepare the empty milking points while other milking points are still in milking.

To go to Rinsing Standby a double press should applied when the unit is in standby mode. The Unit then displays “CLnS”

It is also possible manage without the central command (although it is not recommended). In such case the units should be set to start up in Rinsing Mode. In that case the main power should be switched before Rinsing to bring all the units to Rinsing mode.

Note: *in old versions (software version lower then 2059) or if parameter 8.2.6 CONCARD is set to 'Old" - the functionality is different.*

Appendix F1 – MILPRO P4C™

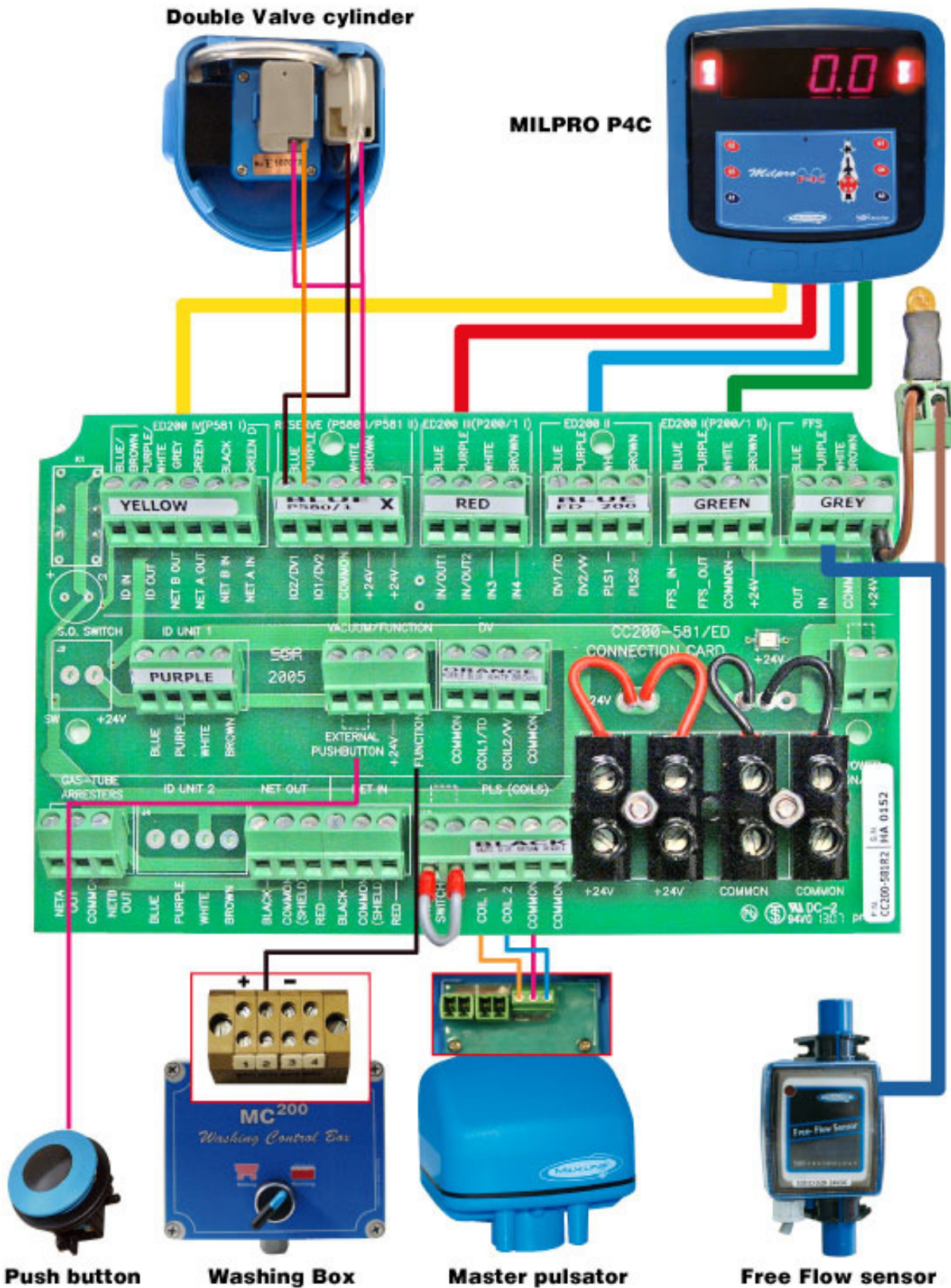



Appendix F2 – MILPRO P4C™ + PULSAMETER 2

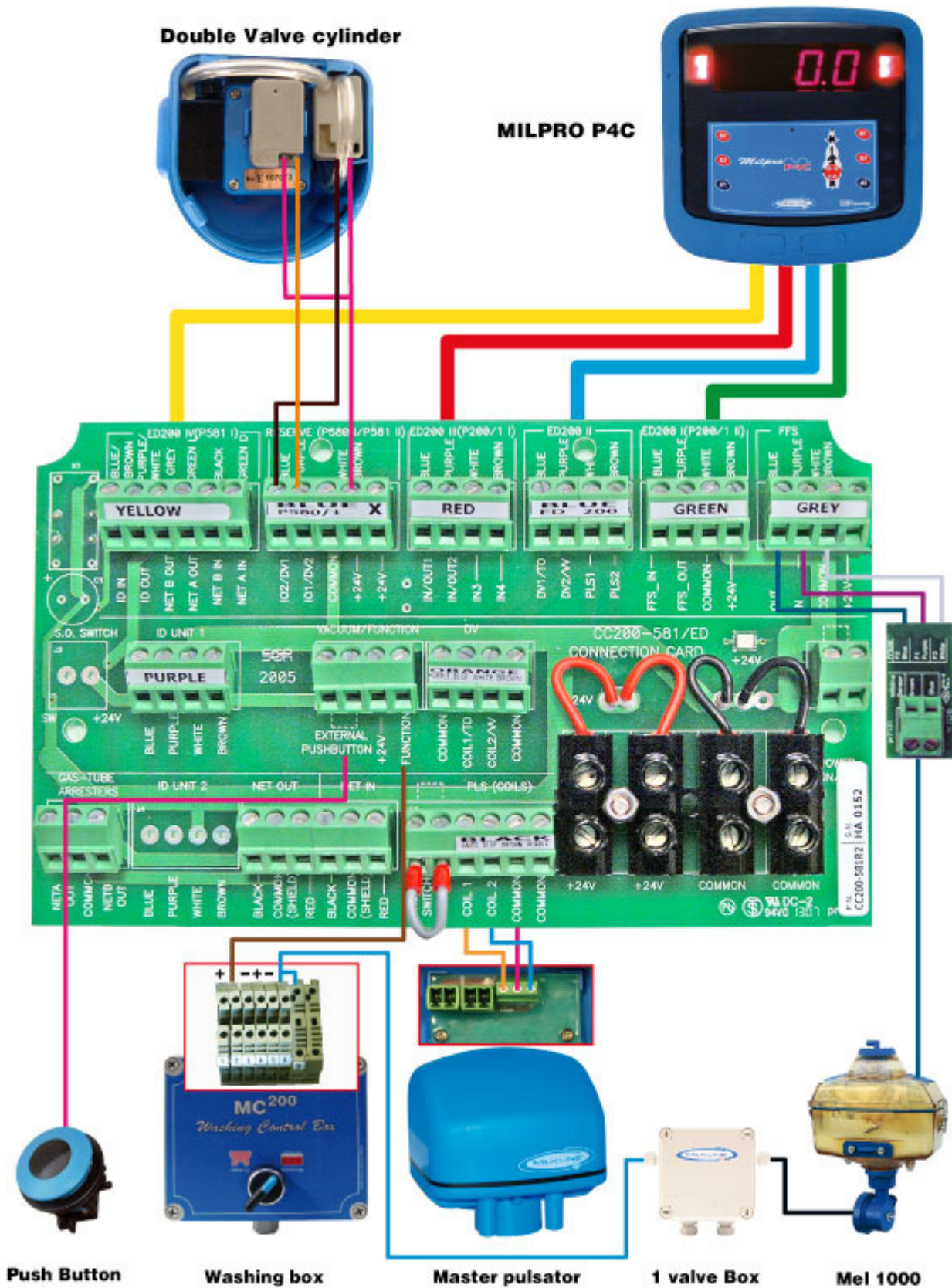

GENERAL PLUGBOARD CHART FOR MAX 30 MILPRO P4C

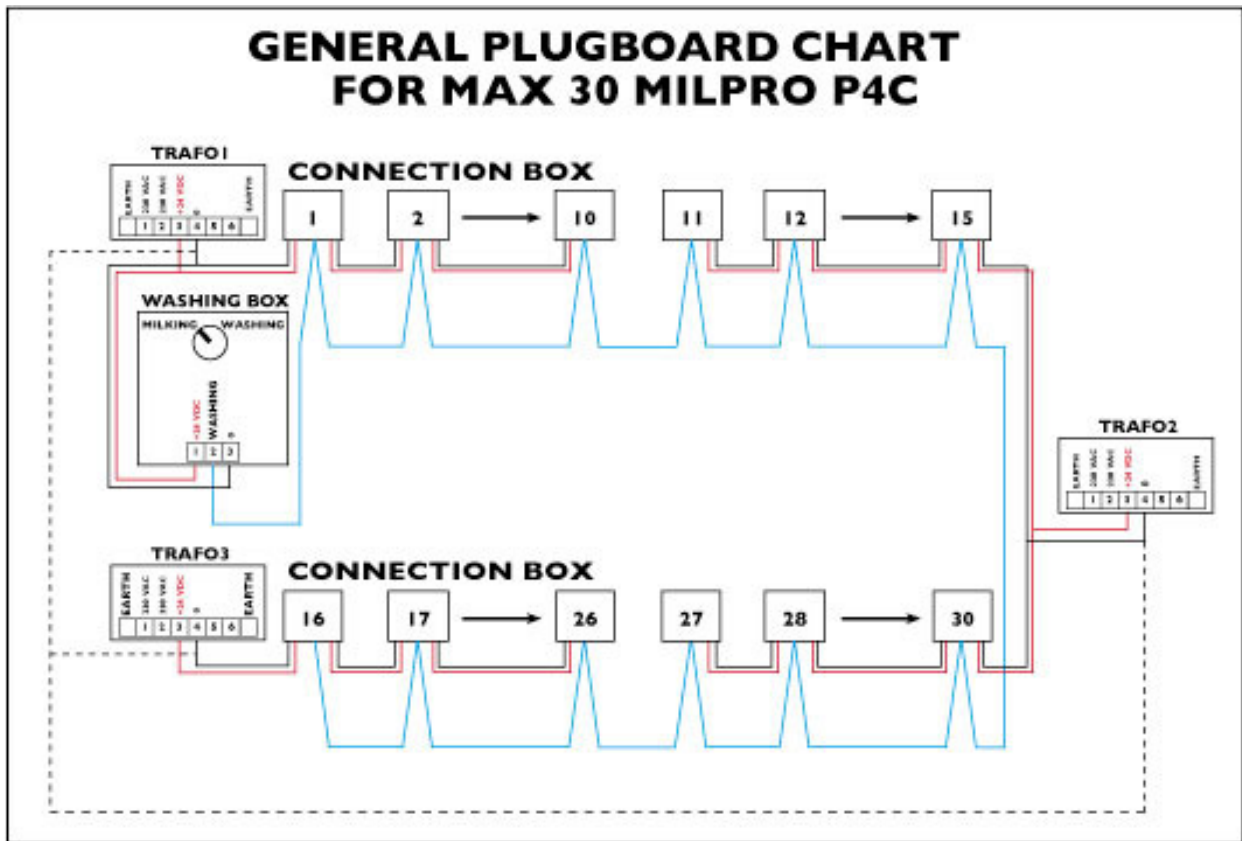

GENERAL PLUGBOARD CHART FOR MAX 40 MILPRO P4C

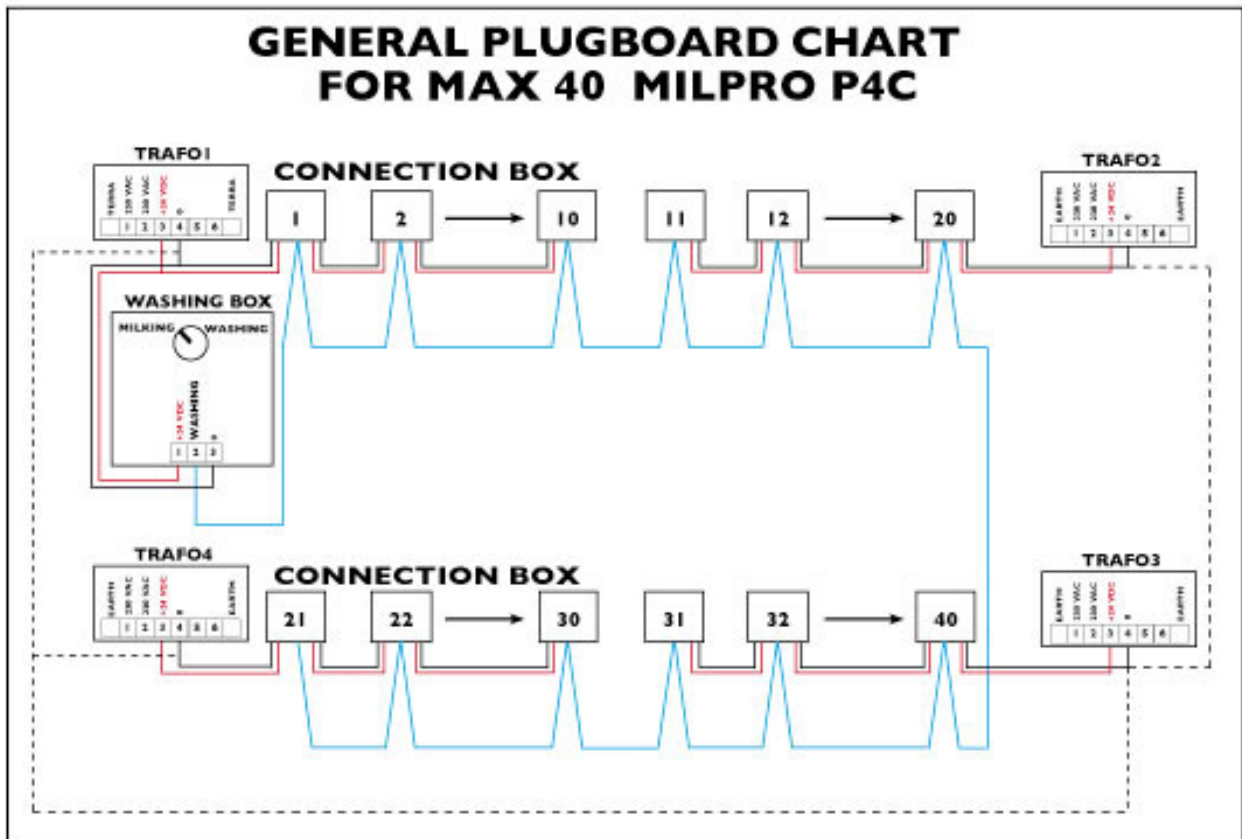

GENERAL PLUGBOARD CHART FOR MAX 10 MILPRO P4C+ Pulsameter 2

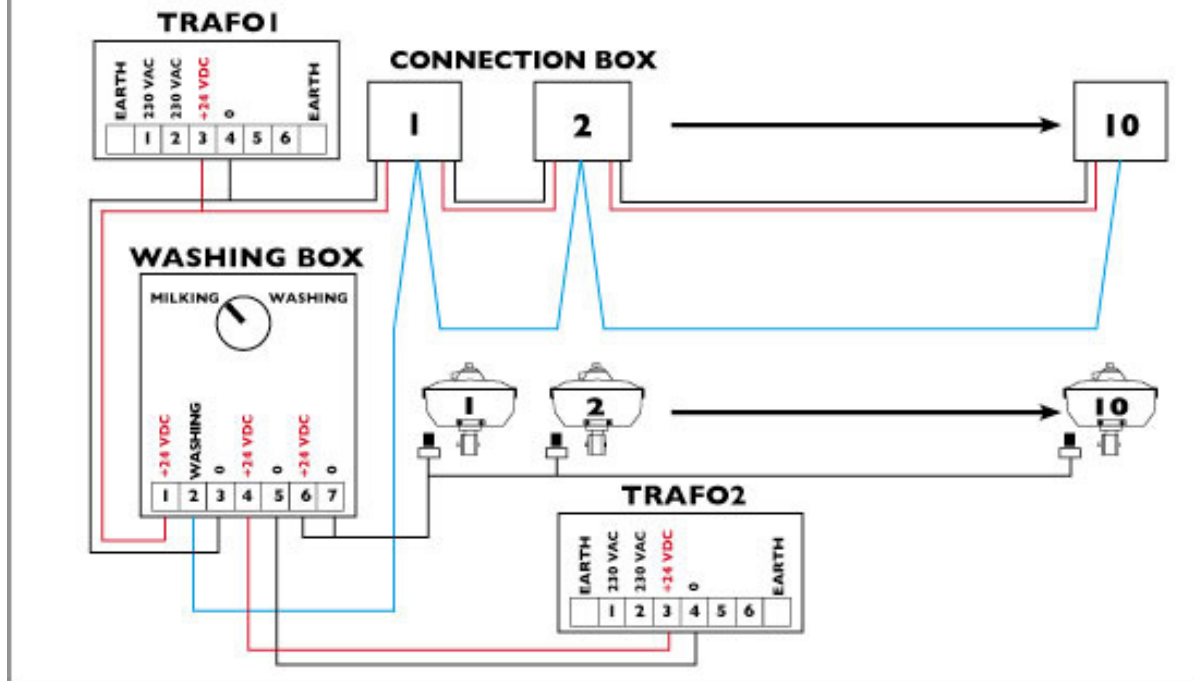

GENERAL PLUGBOARD CHART FOR MAX 20 MILPRO P4C+ Pulsameter 2

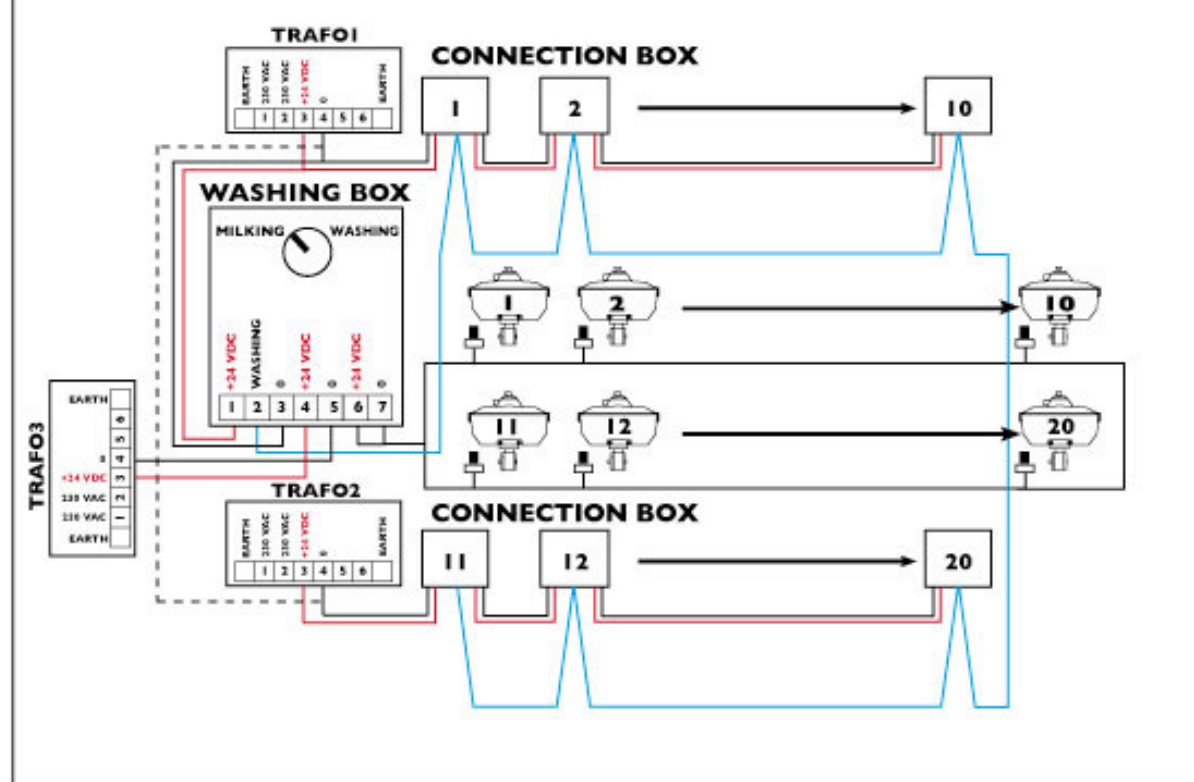

PLUGBOARD CHART FOR MAX 30 MILPRO P4C+ Pulsameter 2

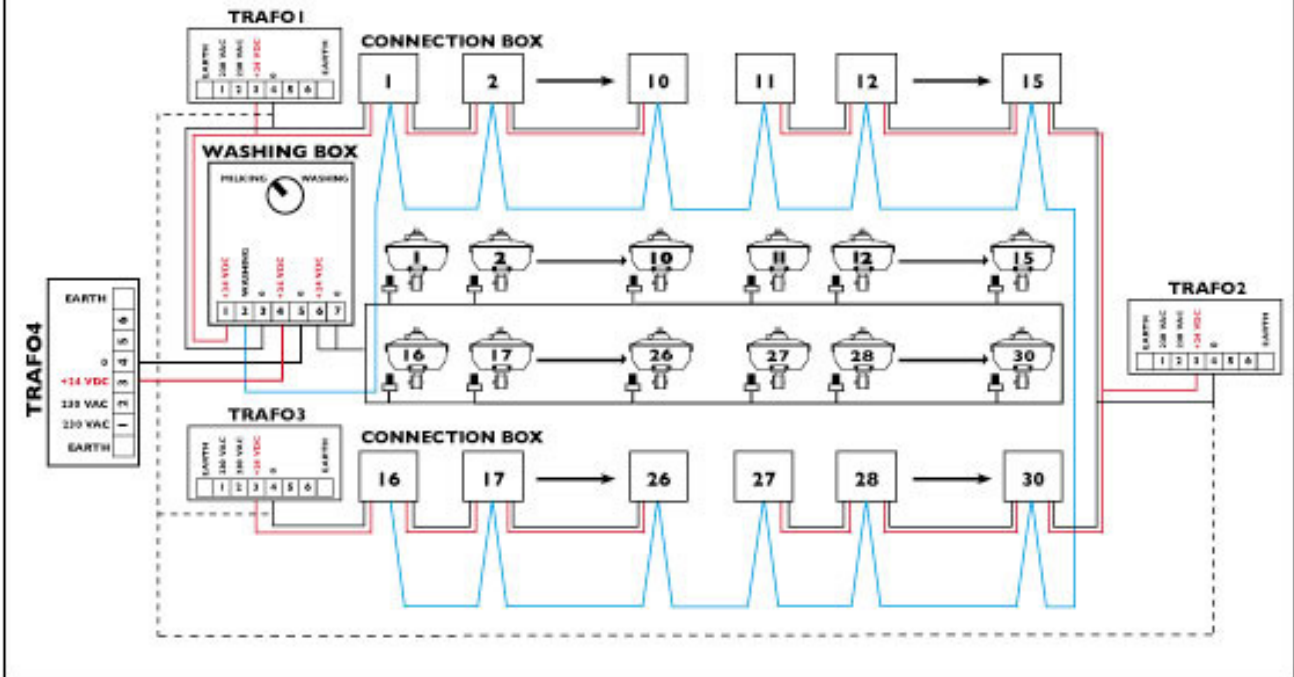

PLUGBOARD CHART FOR MAX 40 MILPRO P4C+ Pulsameter 2

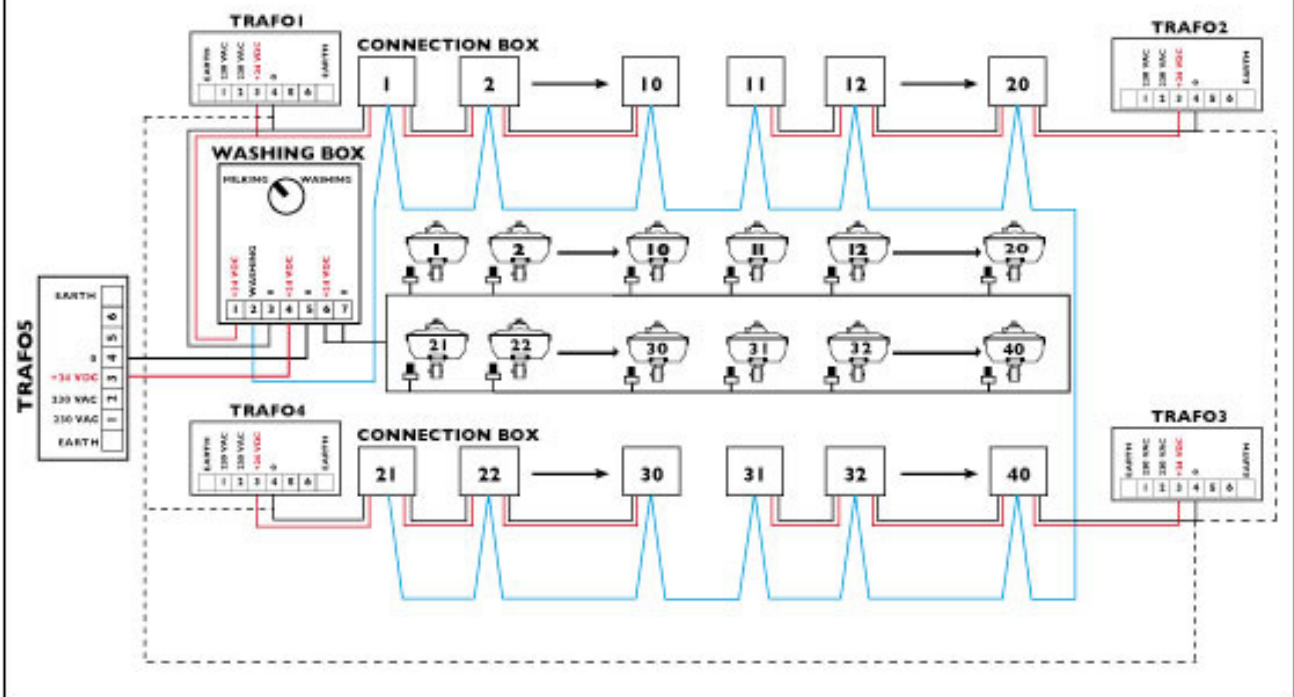

Appendix H – Spare parts

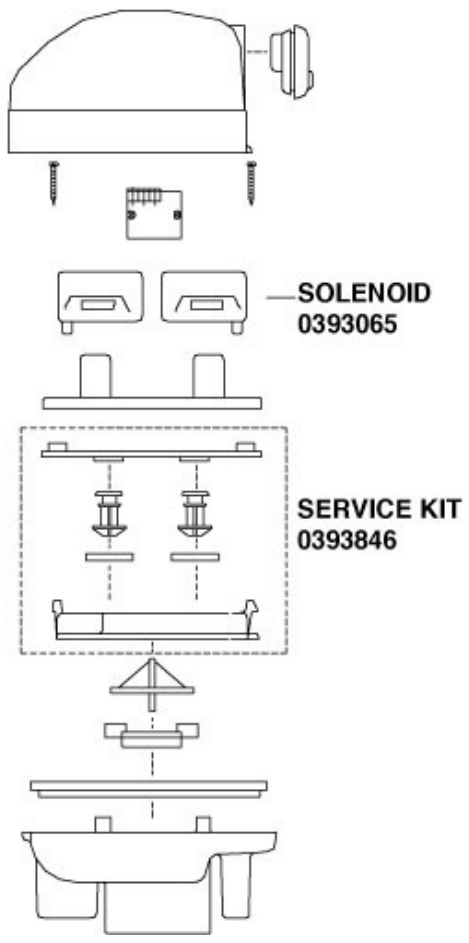

COD. 0393830M
MASTER EL. PULS. SERVO-PULSE

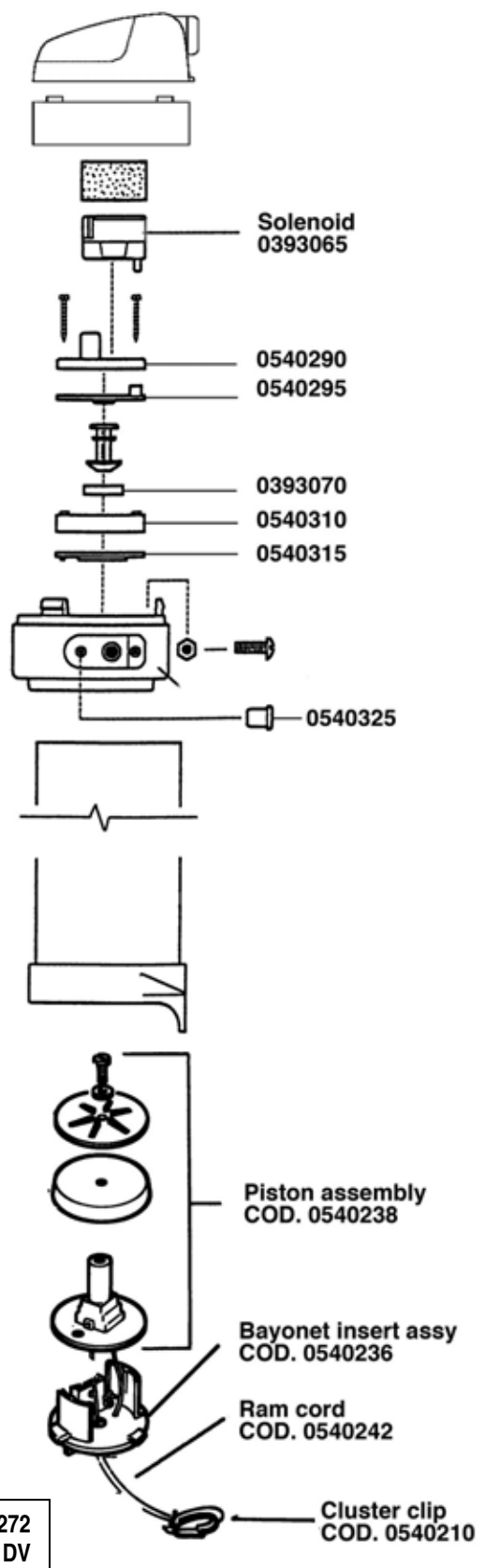

COD. 0540272
TCR COMPLETE PVC ML DV

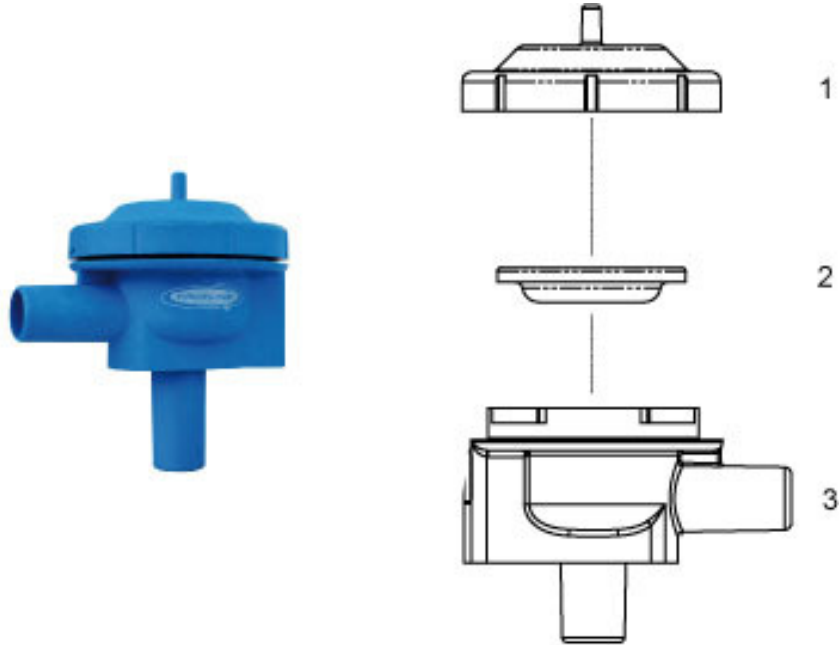

0540610 Vacuum valve	
1	0540614
2	0540616
3	0540602

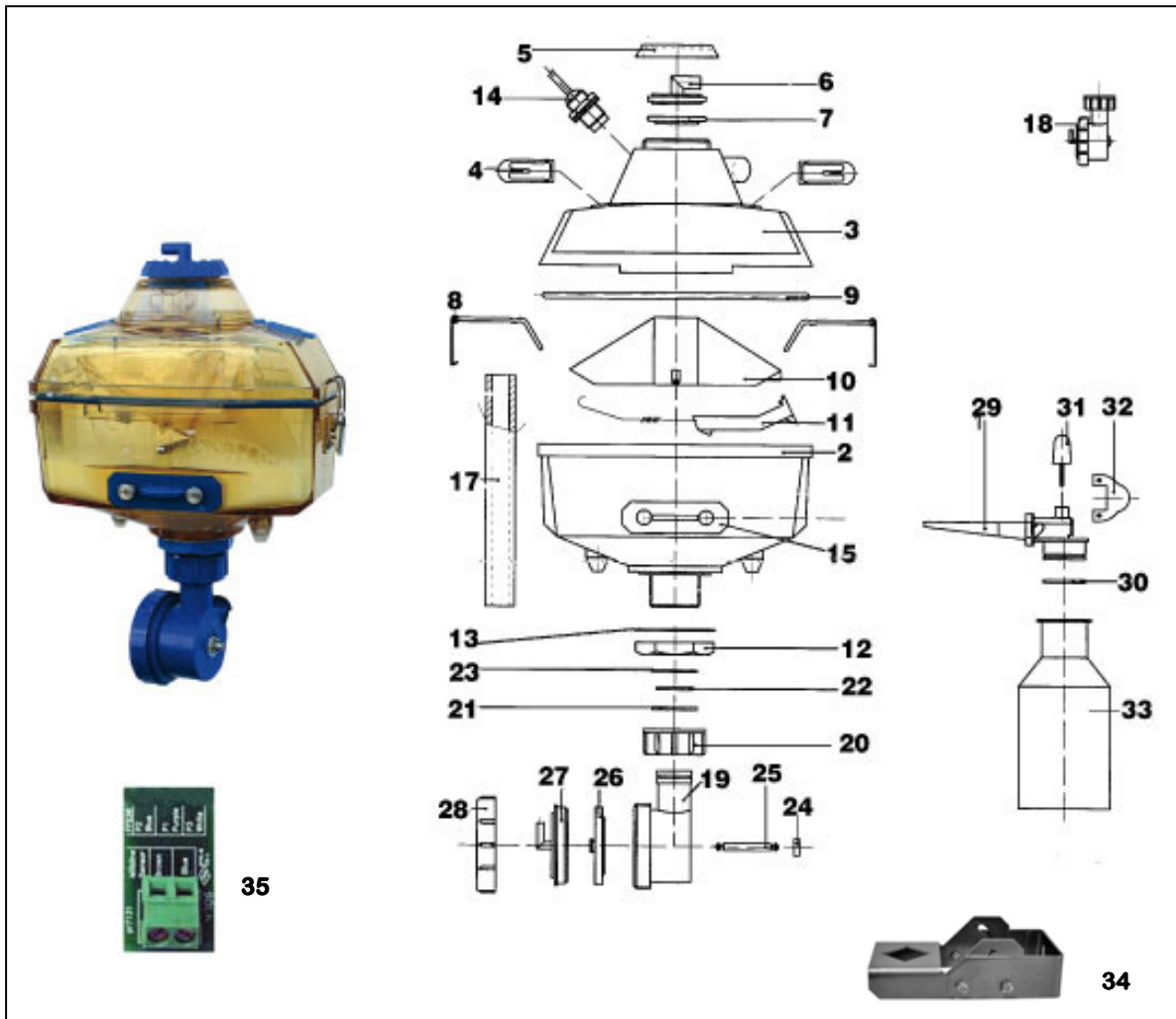

I-AL4535 PULSAMETER 2					
2	I-GL4605	12	I-GL4624	25	I-GL4654
3	I-GL4608 LEFT	13	I-GL4627	26	I-GL4657
3	I-GL4609 RIGHT	14	I-GL4699	27	I-GL4651
5	I-GL4621	15	I-GL4678	28	I-GL4648
6	I-GL4615	18	I-GL4642	29	I-GL4684
7	I-GL4672	19	I-GL4639	30	I-GL4687
8	I-GL4675	20	I-GL4645	31	I-GL4696
9	I-GL4618	21	I-GL4666	32	I-GL4690
10	I-GL4630	22	I-GL4669	33	I-GL4693
11	I-GL4633	23	I-GL4660	34	I-PZ2078
		24	I-GL4663	35	0393721